

QSS Network Service

- NetOrder TCP/IP Interface Version -

- Version 2.2.0.0 -

Revision History

Revision date	Contents
Aug. 8, 2002	Newly created (Ver 1.0.3.3)
Sept. 2, 2002	Release version 1.0.4.
Sept. 27, 2002	Member variables PaperWidth and PaperLength, Surface are added to QSS_FRAME_PARAM structure. Reference number (RefId) is added to WSQSS_FRAME_PARAM, WSQSS_ORDER_PARAM, and WSQSS_ORDER_STATE structures.
Nov. 1, 2002	Command ID 0DH that enables to cancel orders based on reference number is added. Release version 1.0.5. Command ID 0EH that is capable of getting order status based on the reference number is added. Δ2 Command ID 0FH that is capable of getting order history. Δ2 IPAddress, Port, Version, and Level are added to QSS_CLIENT_INFO structure. Δ2 QSS_ORDER_PRINTED and QSS_ORDER_CANCELED are added to QrderState. Δ2
Nov. 26, 2002	IPAddress is added to WSQSS_FRAME_PARAM structure. Δ3 Values to be set to PrintSize of WSQSS_FRAME_PARAM structure are changed. Δ3 PaperLength is available in WSQSS_FRAME_PARAM structure. Δ3 QSS_ORDER_STATE structure is now in the original state, and WSQSS_ORDER_STATE_EX structure is added instead. Δ3 Description for response message to command ID 0EH is changed. Δ3
Dec. 19, 2002	Restrictions were added to command ID's 08H and 0EH. This is because there are cases where these commands do not function properly due to the restriction of RPC. Δ4
Oct. 30, 2003	Version 1.0.6 was released.
Nov. 12, 2003	SorterNum was added as a member to WSQSS_ORDER_PARAM structure. Δ5 Allowable ranges were defined to request number of request messages of command ID's 04H and 05H. Δ6 Allowable range was defined to reference number of request message of command ID 0DH. Δ6 Allowable ranges were defined to OrderNo of WQSS_FRAME_PARAM, WQSS_ORDER_PARAM, and WQSS_ORDER_STATE structures. Δ6 Allowable range was defined to RefId of WQSS_ORDER_STATE_EX structure. Δ6
Mar. 23, 2004	QSS-32 and QSS-33 were included in the models that support IndexPrintFlag of WSQSS_ORDER_PARAM structure. Δ7 QSS_INDEX_CD40, QSS_INDEX_CD40A, QSS_INDEX_CD40B, QSS_INDEX_3WL, and QSS_INDEX_3WL_18 were added to IndexPrintFlag of WSQSS_ORDER_PARAM structure. Δ7 A description was added to describe that QSS-30 does not support SorterNum of WSQSS_ORDER_PARAM structure. Δ7 QSS_MAGAZINE_C was added to MagazineState of WSQSS_PAPER_INFO structure. Δ7 QSS_PRINTTYPE_LONG was added to PrintType of WSQSS_PRINT_CHANNEL structure. Δ7 QSS_INPMEDIA_CTERM, QSS_INPMEDIA_RDS, QSS_INPMEDIA_SD, QSS_INPMEDIA_MS, QSS_INPMEDIA_STORAGE, and QSS_INPMEDIA_USB were added to InpMediaType of WSQSS_PRINT_CHANNEL structure. Δ7 QSS_INDEX_CD40, QSS_INDEX_CD40A, QSS_INDEX_CD40B, QSS_INDEX_3WL, and QSS_INDEX_3WL_18 were added to IDPSize of WSQSS_PRINT_CHANNEL structure. Δ7 QSS_OUTPMEDIA_SD, QSS_OUTPMEDIA_MS, QSS_OUTPMEDIA_BRAVO, and QSS_OUTPMEDIA_USB were added to OutMediaSw of WSQSS_PRINT_CHANNEL structure. Δ7
Apr. 26, 2004	QSS_INDEX_4WL_18 was added to IndexPrintFlag of WSQSS_ORDER_PARAM structure. Δ8 QSS_INDEX_4WL_18 was added to IDPSize of WSQSS_PRINT_CHANNEL structure. Δ8

Apr. 27, 2004	<p>Version 2.0.0 was released.</p> <p>Description that it is also possible to start printing as soon as the print data transfer from Client to QSS is completed was added in “Print sequence” as well as the basic print sequence for this case. Δ9</p> <p>Command ID’s 12H and 13H were added so that it is possible to start printing as soon as print data transfer from Client to QSS is completed. Δ9</p>
May 11, 2004	<p>Application header size was corrected in “2. Application data structure” (32 to 16). Δ9</p>
Aug. 03, 2004	<p>Return value for WSQSS_RESULT structure was corrected. Δ10</p> <p>Reasons are:</p> <ul style="list-style-type: none"> - NetOrder print is now available in not only NetOrder mode but also normal mode. Δ10-1 - When image file is found to be illegal with the fast print, an error will be returned to the Client as with R2R. Δ10-2, Δ10-3
Sept. 06, 2004	<ul style="list-style-type: none"> - Description of “Fast Print” was added. Δ12-1 - A description was added to Command 12H and Command 13H. Δ12-2, Δ12-3 - Description of CvpString1 and CvpString2 were corrected. Δ12-4, Δ12-11 - QSS_INPMEDIA_XD_CARD, QSS_INPMEDIA_MINI_SD, and QSS_INPMEDIA_MS_DUO were added to InpMediaType of WSQSS_PRINT_CHANNEL structure. Δ12-5, Δ12-6, Δ12-7 - QSS_OUTPMEDIA_XD_CARD, QSS_OUTPMEDIA_MINI_SD, and QSS_OUTPMEDIA_MS_DUO were added to OutMediaSw of WSQSS_PRINT_CHANNEL structure. Δ12-8, Δ12-9, Δ12-10 - Noritsu Character Code Tables were added. Δ12-12
Dec.16, 2004	<ul style="list-style-type: none"> - Index R12 was added. Δ13-1, Δ13-2 - The following variables were added to WSQSS_PRINTER_STATE. <ol style="list-style-type: none"> 1. IsNetOrderMode Δ13-3 2. IsCalibrationMode Δ13-4 - The maximum possible value of FrameNum and FrameNo for WSQSS_FRAME_PARAM2 was extended from 999 to 9999. Δ13-5, Δ13-6 - The maximum possible value of FrameNum for WSQSS_ORDER_PARAM2 was extended from 999 to 9999. Δ13-7
2005.03.23	<ul style="list-style-type: none"> - Description was added to command ID 05H. Δ14-1 - Description of Status of the WSQSS_ORDER_HISTORY structure was corrected. <ul style="list-style-type: none"> QSS_ORDER_STATUS_PRINTED -> QSS_ORDER_PRINTED Δ14-2 QSS_ORDER_STATUS_CANCELED -> QSS_ORDER_NONE Δ14-3
Apr. 14, 2005	<p>Some incorrect statements were corrected. Δ15</p>
Apr. 18, 2005	<ul style="list-style-type: none"> - QSS_INPMEDIA_DVD_ROM was added to InpMediaType of the WSQSS_PRINT_CHANNEL structure. Δ16-1 - QSS_OUTPMEDIA_DVD_ROM was added to OutMediaSw of the WSQSS_PRINT_CHANNEL structure. Δ16-2
Apr. 18, 2005	<ul style="list-style-type: none"> - Rotate of the WSQSS_FRAME_PARAM2 structure is now available to allow every input image to be rotated. Δ17-1, Δ17-7 - The following variables were added to the WSQSS_FRAME_PARAM2 structure to allow every input image to be cropped. <ol style="list-style-type: none"> 1. TrimStartPointX Δ17-2, Δ17-8 2. TrimStartPointY Δ17-3, Δ17-9

- 3. TrimSizeX Δ 17-4, Δ 17-10
 - 4. TrimSizeY Δ 17-5, Δ 17-11
 - 5. TrimUnitSize Δ 17-6, Δ 17-12
- Apr. 18, 2005 - The following variables were added to the WSQSS_ORDER_PARAM2 structure.
- 1. IndexPrintNum Δ 18-1, Δ 18-16
 - 2. OutMediaFlg Δ 18-2, Δ 18-17
 - 3. OutMediaFormat Δ 18-3, Δ 18-18
 - 4. OutMediaNum Δ 18-4, Δ 18-19
 - 5. OutMediaQualityType Δ 18-5, Δ 18-20
 - 6. OutMediaQuality Δ 18-6, Δ 18-21
 - 7. OutMediaSize Δ 18-7, Δ 18-22
 - 8. OutMediaViewer Δ 18-8, Δ 18-23
 - 9. LabelIndexPrintFlg Δ 18-9, Δ 18-24
 - 10. LabelIndexPrintNum Δ 18-10, Δ 18-25
 - 11. LabelIndexPaperWidth Δ 18-11, Δ 18-26
 - 12. LabelIndexSurface Δ 18-12, Δ 18-27
 - 13. Priority Δ 18-13, Δ 18-28
 - 14. PrintMode Δ 18-14, Δ 18-29
 - 15. Wait Δ 18-15, Δ 18-30
- Apr. 18, 2005 - FinishTime was added to the following structures:
- WSQSS_ORDER_STATE Δ 19-1, Δ 19-2
 - WSQSS_ORDER_STATE_EX Δ 19-3, Δ 19-4
- Apr. 18, 2005 - SystemInfo was added to the WSQSS_PRINTER_INFO structure. Δ 20-1, Δ 20-2
- EnableOutMediaViewer was added to the WSQSS_PRINTER_STATE structure. Δ 20-3, Δ 20-4
 - WithBorder of WSQSS_FRAME_PARAM2 structure is now available. Δ 20-5, Δ 20-7
 - Save was added to the WSQSS_FRAME_PARAM2 structure. Δ 20-6, Δ 20-8
 - QSS_INVALID_OUTMEDIA_PARAM was added as a return value of the WSQSS_RESULT structure. Δ 20-9
- Apr. 18, 2005 - Descriptions were added to the following values of the WSQSS_ORDER_PARAM2 structure:
- IndexPrintNum Δ 21-1
 - OutMediaQualityType Δ 21-2
 - OutMediaQuality Δ 21-3
 - OutMediaViewer Δ 21-4
 - LabelIndexPrintFlg Δ 21-5
 - Priority Δ 21-6
- QSS_INVALID_PARAMETER was added as a return value of the WSQSS_RESULT structure. Δ 21-7
- May 23, 2005 - EnablePriority was added to the WSQSS_ORDER_PARAM2 structure. Δ 22
- Jun. 08, 2005 - Possible value for QSS_PRIORITY_NORMAL of Priority of the WSQSS_ORDER_PARAM2 structure was extended.
- 150 – 249 -> 200 – 299 Δ 23-1
- The following values were added to Priority of the WSQSS_ORDER_PARAM2 structure.
 - QSS_PRIORITY_LOW Δ 23-2
 - QSS_PRIORITY_NONE Δ 23-3

Oct.17, 2005	<ul style="list-style-type: none"> - Version 2.1.0 was released. - In the WSQSS_FRAME_PARAM structure, <ul style="list-style-type: none"> WithBorder was made available. Δ24-1, Δ24-6 PaperFittingFlg was made available. Δ24-2, Δ24-7 Way was added. Δ24-3, Δ24-8 Reserve2 was added. Δ24-4, Δ24-9 EnablePaperFittingFlg was added. Δ24-5, Δ24-10 - In the WSQSS_FRAME_PARAM2 structure, <ul style="list-style-type: none"> PaperFittingFlg was made available. Δ24-11, Δ24-13 EnablePaperFittingFlg was added. Δ24-12, Δ24-14
Jan. 25, 2006	<ul style="list-style-type: none"> - Version 2.2.0 was released. - QSS_MAGAZINE_A2 was added to MagazineState of WSQSS_PAPER_INFO structure. Δ25-1 - Description for PaperRemaind in WSQSS_PAPER_INFO structure was corrected. Δ25-2 - In the WSQSS_ORDER_PARSM2 structure, <ul style="list-style-type: none"> PaperWidthD and SurfaceD were added. Δ25-3, Δ25-4, Δ25-5, Δ25-6, Δ25-7, Δ25-8, Δ25-9 - In the WSQSS_FRAME_PARAM2, <ul style="list-style-type: none"> FrontPrintString and FrontPrintFlg were added. Δ25-10, Δ25-11, Δ25-12, Δ25-13, Δ25-14 - In the WSQSS_ORDER_PARSM2 structure, <ul style="list-style-type: none"> Comment was made available. Δ25-15, Δ25-16
Feb. 14, 2006	<ul style="list-style-type: none"> - Description of FrontPrintString of the QSS_FRAME_PARAM2 structure was corrected. Δ26-1 <ul style="list-style-type: none"> “19 characters can be set at maximum” -> “31 characters can be set at maximum”
June 24, 2008	<ul style="list-style-type: none"> - Corrected the unit of Resolut of WSQSS_PAPER_INFO structure.

Table of Contents

1. Overview	7
Introduction	7
Environment.....	7
Communication Sequence	7
Packet Structure	7
Communication Command List:.....	13
Command ID: 01H (Get QSS model name and interface version)	15
Command ID: 02H (Send print data to QSS)	16
Command ID: 03H (Spool order)	17
Command ID: 04H (Cancel order)	18
Command ID: 05H (PU output).....	19
Command ID: 06H (Get paper information).....	20
Command ID: 07H (Get error/attention message).....	21
Command ID: 08H (Get order status).....	22
Command ID: 09H (Get QSS status)	24
Command ID: 0AH (Get print channel information)	25
Command ID: 0BH (Get total number of prints or total amount of replenisher solution).....	26
Command ID: 0CH (Get profile information)	27
Command ID: 0DH (Cancel order).....	28
Command ID: 0EH (Get order status) $\Delta 2$	29
Command ID: 0FH (Get order history) $\Delta 2$	31
Command ID: 12H (Send print data) $\Delta 9$	33
Command ID: 13H (Spool order) $\Delta 9$	34
3. Structures to be used for communications.....	35
WSQSS_PRINTER_INFO structure	35
WSQSS_CLIENT_INFO structure.....	35
WSQSS_FRAME_PARAM structure	36
WSQSS_ORDER_PARAM structure.....	39
WSQSS_PAPER_INFO structure	42
WSQSS_ERROR_INFO structure.....	43
WSQSS_ORDER_STATE structure	43
WSQSS_ORDER_STATE_EX structure $\Delta 3$	44
WSQSS_PRINTER_STATE structure.....	45
WSQSS_PRINT_CHANNEL structure	47
WSQSS_PU_INFO structure.....	51
WSQSS_SUM_INFO structure	53
WSQSS_PROFILE_INFO structure	54
WSQSS_DATETIME structure $\Delta 2$	55
WSQSS_ORDER_HISTORY structure $\Delta 2$	55
WSQSS_FRAME_PARAM2 structure $\Delta 9$	57
WSQSS_ORDER_PARAM2 structure $\Delta 9$	61
WSQSS_RESULT structure	66
4. QSS Search function	68
Appendix: Noritsu Character Code Table $\Delta 12-12$	70

1. Overview

Introduction

This document describes the interface to enable TCP/IP communication between the external terminals such as server and QSS such as 28, 29, and 30 series on QSS Network Service.

The description in this manual is made on assumption of using Auto Print mode only.

Environment

This interface can be used under the circumstance that the QSS and external terminal (“Client”) are connected via Ethernet and that the TCP/IP setting has been completed.

Communication Sequence

Client sends command request to QSS, and then QSS responds to Client.

During a session, QSS receives only 1 command, so Client has to establish a connection with QSS every time it issues a command request and close the connection upon the completion of the command communication.

NetOrder service (TCP/IP) utilizes port No. 5001.

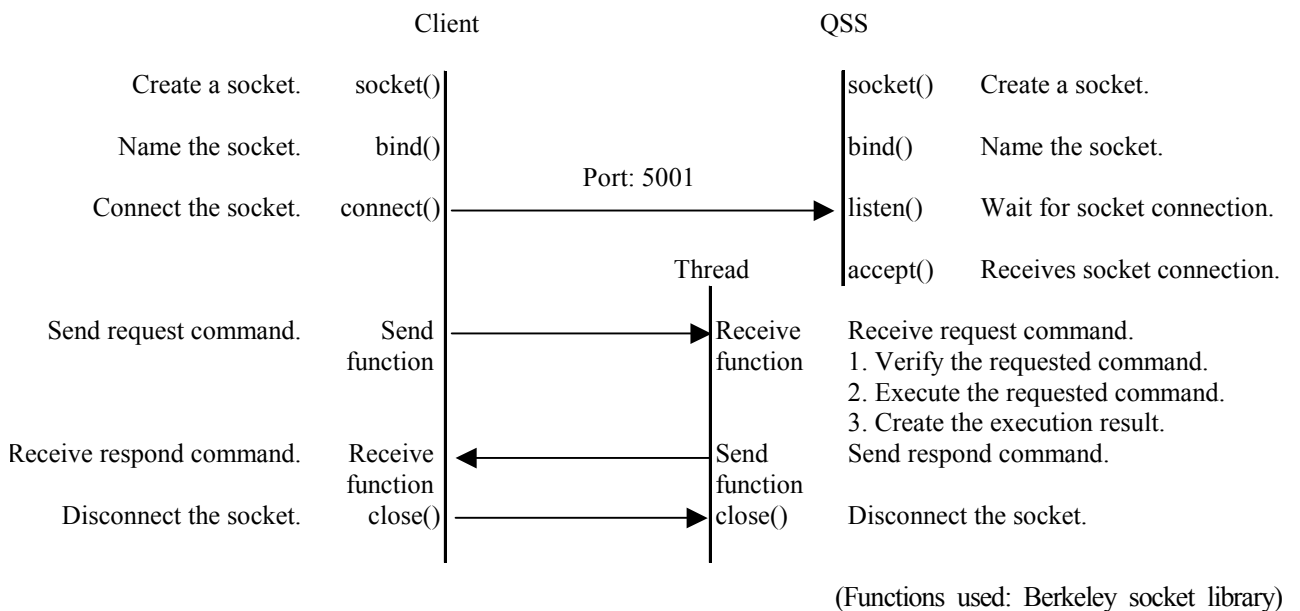

Packet Structure

1. Ethernet Frame

Packet used to send commands have the same structure as the normal TCP/IP packet. This specification explains only the application data, excluding IP, TCP, and Ethernet headers. Refer to Fig. 1 below. (This specification describes the interface in the TCP/IP application layer.)

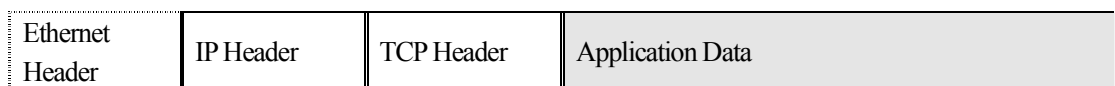

Fig. 1. Ethernet Frame

2. Application Data Structure

Application data consists of application header and user data. Please refer to Fig. 3 for application header and Fig. 4 for user data. (Unit: octet)

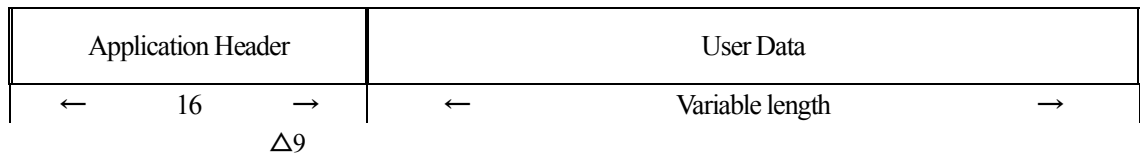

Fig. 2. Application data

NOTE: Byte Order is of Big Endian type.

3. Application Header

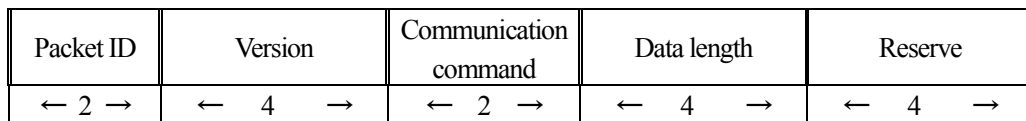

Fig. 3 Application Header

Packet ID

- Defines 514E H (hex).

Version

- Defines the version of this interface specification
In case of version 1.2.3, it appears 01020300 H.

Communication Command

- Communication command consists of command ID and send/receive ID.
Please refer to Communication Command List.

Data length

- Defines the number of byte for user data.

4. User Data

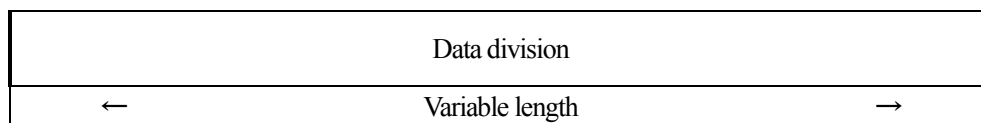

Fig. 4. User Data

Data division

- For the detailed information as to data division, please refer to “2. Communication command and Data division”.

Print Sequence

Below illustrates the basic print sequence.

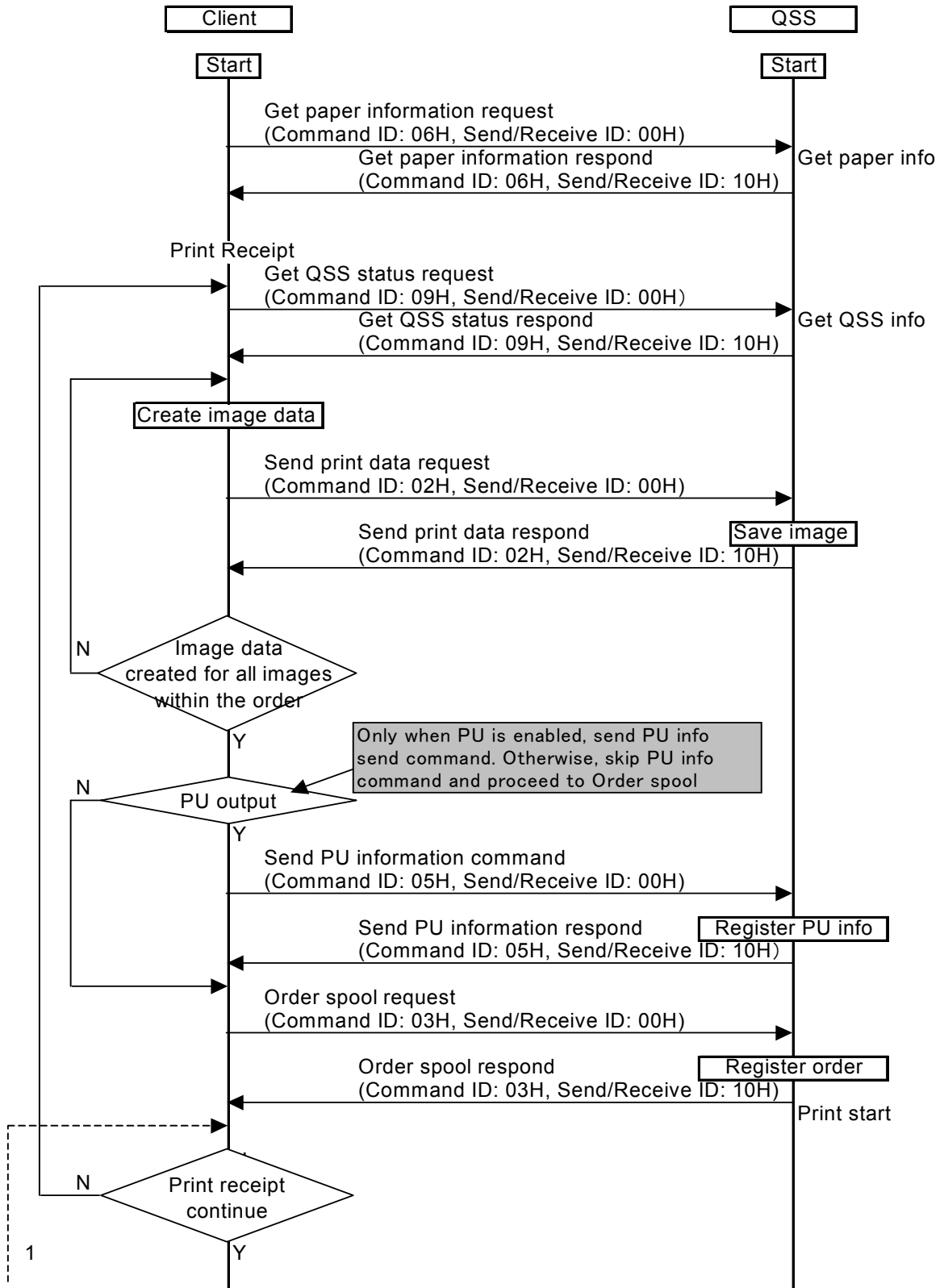

Continued from the previous page

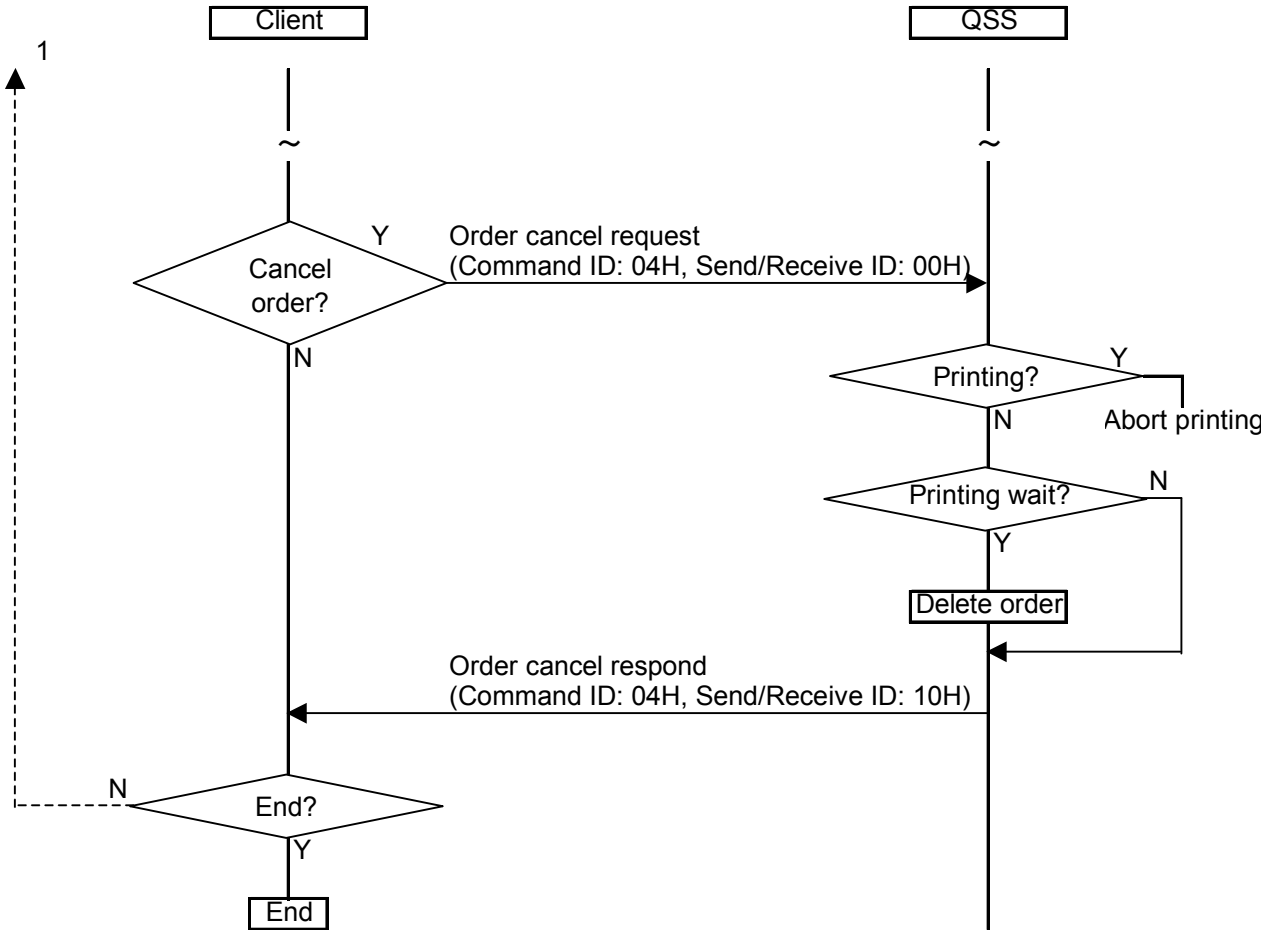

Fast Print △12-1

Fast print makes it possible to start printing as soon as the print data transfer from Client to QSS is completed, which will lead to higher productivity. Below illustrates the basic print sequence of Fast Print.

NOTE: Fast Print function is only available with NetOrder API version 2.00 and on. QSS-28, QSS-29, and QSS-30 do not have this function. △9

Continued from the previous page

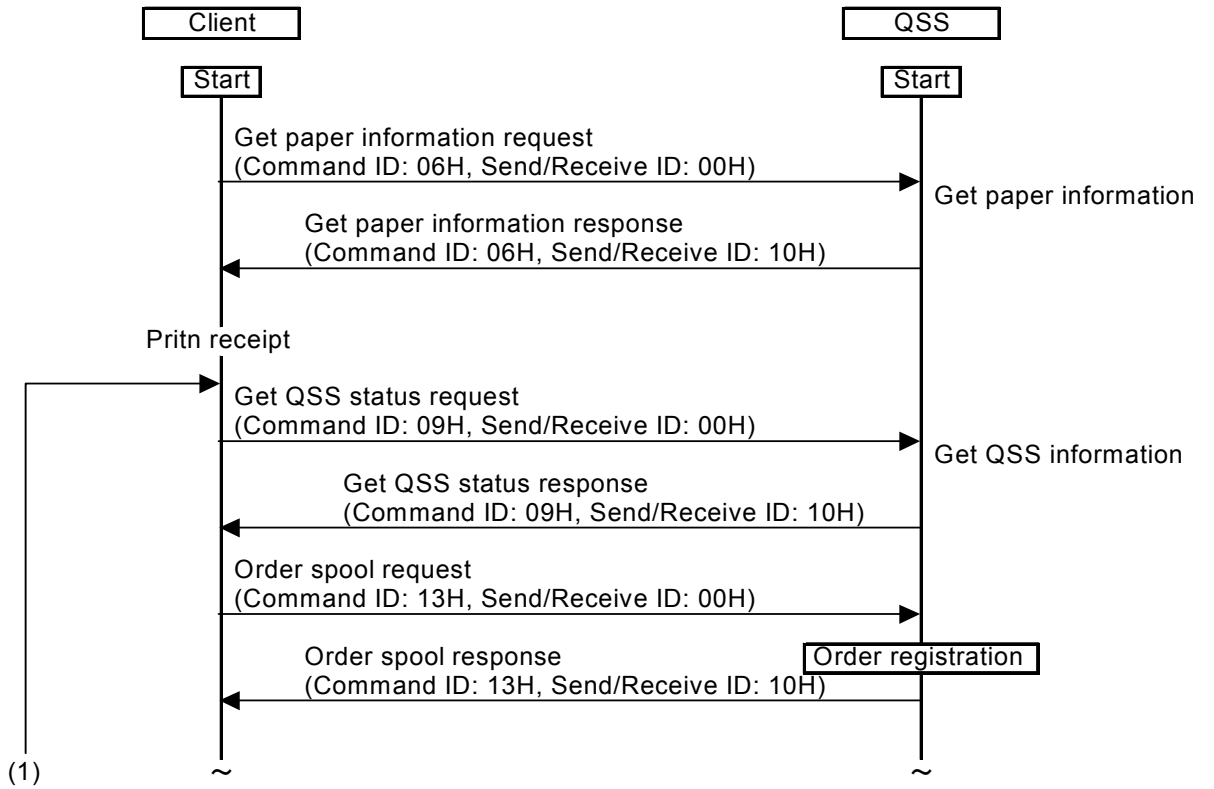

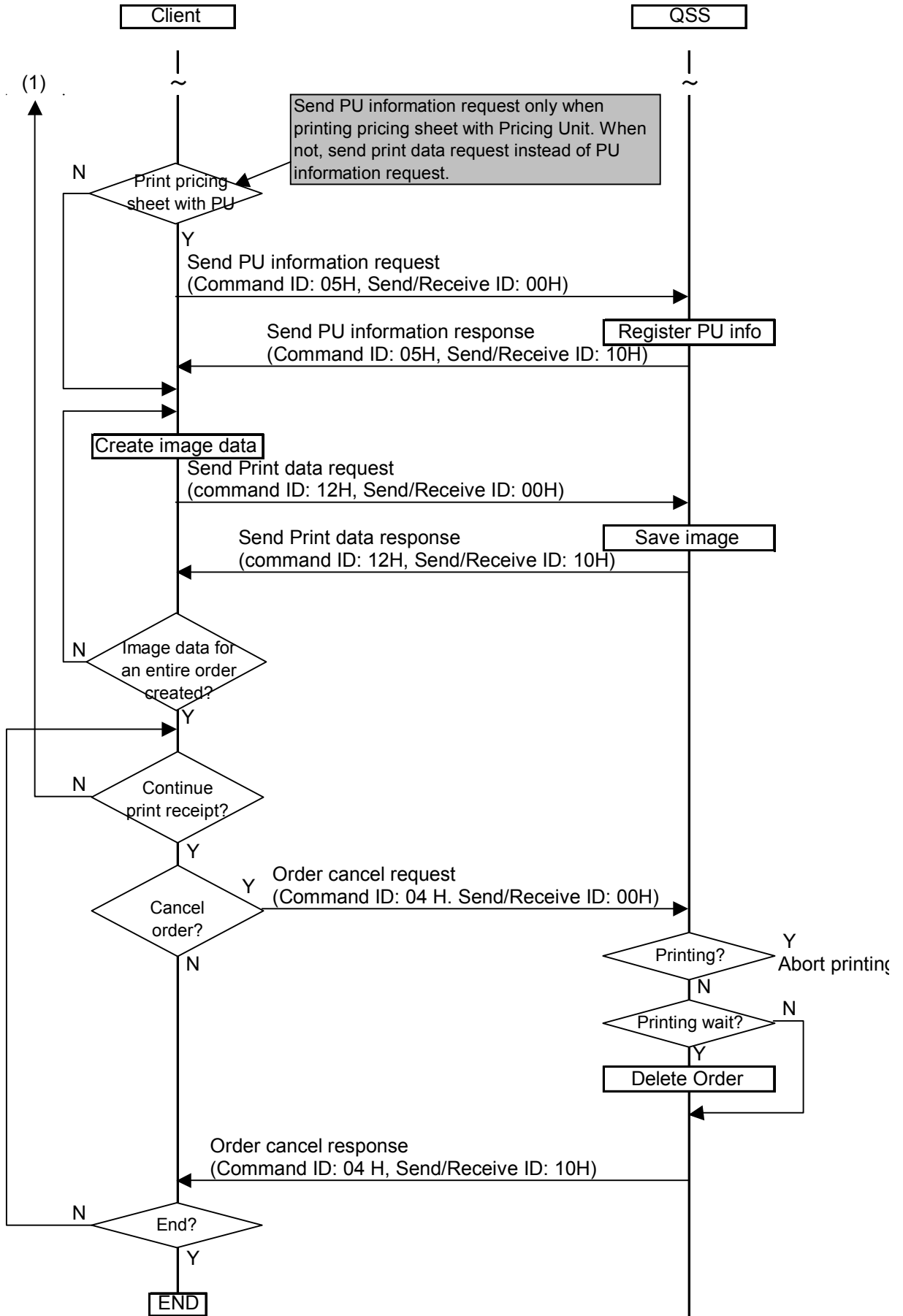

2. Communication commands and Data division

Communication Command List:

Command ID (Hex)	Send/Receive ID (Hex)	Description
01 H		Get QSS model name and interface version.
	00 H	Get model name and interface version request
	10 H	Get model name and interface version response
02 H		Send print data to QSS.
	00 H	Send print data request
	10 H	Send print data response
03 H		Spool order.
	00 H	Spool order request
	10 H	Spool order response
04 H		Cancel spooled order.
	00 H	Cancel order request
	10 H	Cancel order response
05 H		Send information to be printed with Pricing Unit to QSS
	00 H	Send PU information request
	10 H	Send PU information response
06 H		Get information on paper registered.
	00 H	Get paper information request
	10 H	Get paper information response
07 H		Get error and/or attention message currently occur on QSS.
	00 H	Get Error/Attention status request
	10 H	Get Error/Attention status response
08 H		Get status of spooled order.
	00 H	Get order status request
	10 H	Get order status response
09 H		Get current status of QSS
	00 H	Get QSS status request
	10 H	Get QSS status response
0A H		Get print channel information.
	00 H	Get print channel information request
	10 H	Get print channel information response
0B H		Get total number of prints or total amount of replenisher solution.
	00 H	Get number of print/solution amount information request
	10 H	Get number of print/solution amount information response
0C H		Get QSS profile information.
	00 H	Get profile request
	10 H	Get profile response
0DH Δ 1		Cancel spooled order based on the reference number
	00 H	Cancel order request
	10 H	Cancel order response
0EH Δ 2		Get the status of spooled order based on the reference number
	00 H	Get order status request
	10 H	Get order status response
		Get order history

0FH Δ2	00 H	Get order history request
	10 H	Get order history response
12 H Δ9		Send print data to QSS
	00 H	Send print data request
	10 H	Send print data response
13 H Δ9		Spool order
	00 H	Spool order request
	10 H	Spool order response

Command ID: 01H (Get QSS model name and interface version)

Purpose:

Get QSS model name and interface version.

Use this command to confirm the QSS model name and/or interface version of this API.

Send/Receive ID: 00H (Request)

Data division:

None

Send/Receive ID: 10H (Response)

Data division:

Result	QSS information
← 32 Δ15 →	← 64 →

Result:

Refer to [WSQSS_RESULT structure](#).

QSS information:

Refer to [WSQSS_PRINTER_INFO structure](#).

Communication Sequence:

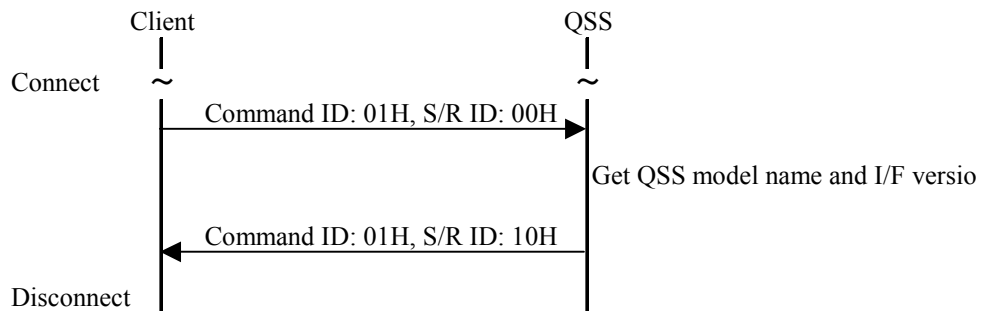

Command ID: 02H (Send print data to QSS)

Purpose:

Send print data to QSS.

In order for Client to request QSS to print, it is required to send print data (image to be printed and parameter needed to print) to QSS first.

Print data sent from Client will be copied to the spool region of QSS. At this time, printing does not start yet. Send command ID: 03H to initiate printing.

Print data stored in spool region will be deleted upon completion of printing. Print data will also be deleted when command ID: 03H is not sent within 10 minutes after print data is stored in spool region.

Send/Receive ID: 00H (Request)

Data division:

Client Information	Frame Print Parameter Information	Image Data
← 96 →	← 320 →	← Variable →

Client Information:

Refer to [WSQSS_CLIENT_INFO structure](#).

Frame Print Parameter Information:

Refer to [WSQSS_FRAME_PARAM structure](#).

Image Data:

Defines image data to be printed

NOTE: Define image data length to FileSize in WSQSS_FRAME_PARAM structure.

Send/Receive ID: 10H (Response)

Data division:

Result
← 32 Δ15 →

Result:

Refer to [WSQSS_RESULT structure](#).

Communication Sequence:

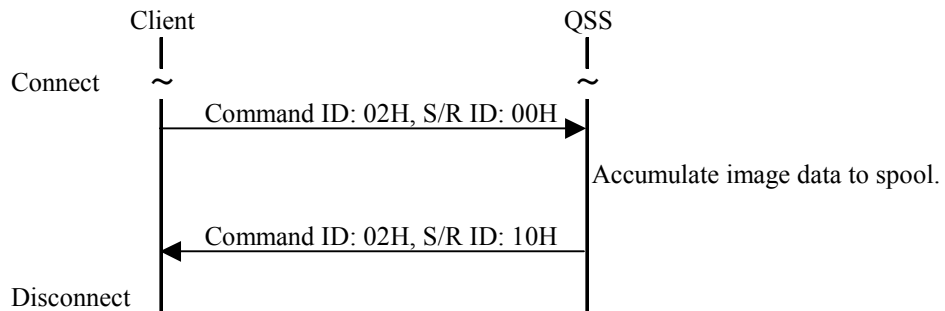

Command ID: 03H (Spool order)

Purpose:

Spool order.

QSS controls print request in units of order. Therefore, every time image file is sent with command ID: 02H, it is required to send this command subsequently in order to spool the order. Every order will be copied to the spool regions with this command and wait for printing to be implemented.

Send/Receive ID: 00H (Request)

Data division:

Client Information	Order Print Parameter Information
← 96 →	← 64 →

Client Information:

Refer to [WSQSS_CLIENT_INFO structure](#).

Order Print Parameter Information:

Refer to [WSQSS_ORDER_PARAM structure](#).

Send/Receive ID: 10H (Response)

Data division:

Result
← 32 Δ15 →

Result:

Refer to [WSQSS_RESULT structure](#).

Communication Sequence:

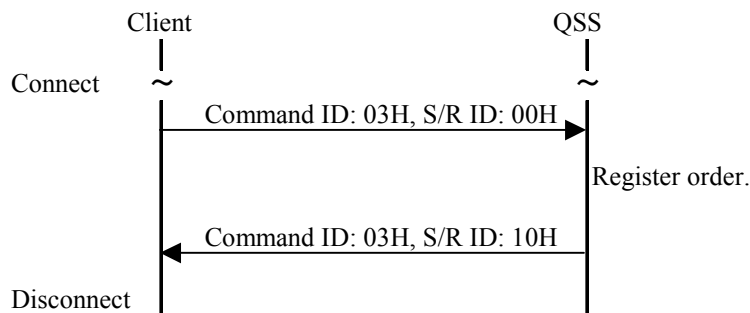

Command ID: 04H (Cancel order)

Purpose:

Cancel spooled order.

Spooled order in print queue and order being printed and their print data can be deleted with this command ID.

When deleting an order, print interruption process is executed on QSS first, and, upon completion of this process, the order will be deleted. This command will return the result to Client without waiting for the completion of print interruption process. Whether order has been deleted or not can be determined by calling command ID: 08H.

Send/Receive ID: 00H (Request)

Data division:

Client Information	Request Number
← 96 →	← 2 →

Client Information:

Refer to [WSQSS_CLIENT_INFO structure](#).

Request Number:

(unsigned long)

Defines the request number of the order to be deleted.

The range is 0 – 65534.

△6

Send/Receive ID: 10H (Response)

Data division:

Result
← 32 △15 →

Result:

Refer to [WSQSS_RESULT structure](#).

Communication Sequence:

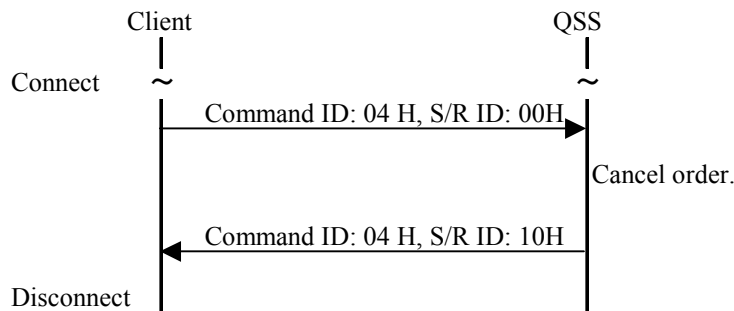

Command ID: 05H (PU output)

Purpose:

Send information to be printed on pricing sheet by Pricing Unit to QSS.

Send information to be printed out on pricing sheet issued with PU (Pricing Unit) connected to QSS. Pricing sheet will be printed out upon the completion of printing of the order (a pricing sheet per order).

PU is an optional accessory of QSS. When PU is not registered in the Option Registration mode of the QSS, or when the specified PU is not of the type that will print out the receipt on the PU, QSS_NOT_CONNECTED_PU is returned as the result. △14-1

Option registration of PU can be performed on QSS Option Registration screen.

Send/Receive ID: 00H (Request)

Data division:

Client Information	Request number	PU output information
← 96 →	← 2 →	← 128 →

Client Information:

Refer to [WSQSS_CLIENT_INFO structure](#).

Request number:

(unsigned long)

Defines the request number of the order whose information will be printed out on PU.

The range is 0 – 65534.

△6

PU output information:

Refer to [WSQSS_PU_INFO structure](#).

Send/Receive ID: 10H (Response)

Data division

Result
← 32 △15 →

Result

Refer to [WSQSS_RESULT structure](#).

Communication Sequence:

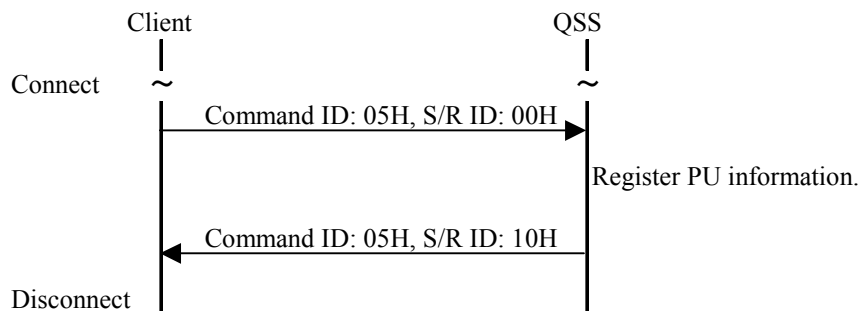

Command ID: 06H (Get paper information)

Purpose:

Get the information on paper registered.

Paper information of the paper magazine currently installed on QSS or registered will be acquired with get flag. It is required for Client, when setting order parameter, to call command ID: 06H to confirm the paper currently registered on the QSS.

Send/Receive ID: 00H (Request)

Data division:

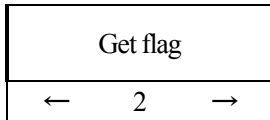

Get flag: (unsigned long)

Defines which paper information you wish to get from the following:

0000H: Get information of the paper of the paper magazine currently installed on QSS.

0001H: Get information of the paper registered on QSS.

Send/Receive ID: 10H (Response)

Data division:

Result	Total number of information to get	Sequence ID	Paper information
← 32 Δ15 →	← 4 →	← 4 →	← 64 →

Result:

Refer to [WSQSS_RESULT structure](#).

Total number of information to get: (unsigned long)

Number of paper whose information corresponds to the get flag.

QSS will send paper information for each paper respectively, so please receive it successively.

NOTE: When there is no corresponding paper information, 0 will be defined.

Sequence ID: (unsigned long)

ID is assigned that starts with 1 and increments up to the number of paper whose information is to be got.

Paper information:

Refer to [WSQSS_PAPER_INFO structure](#). Δ15-2

Communication Sequence:

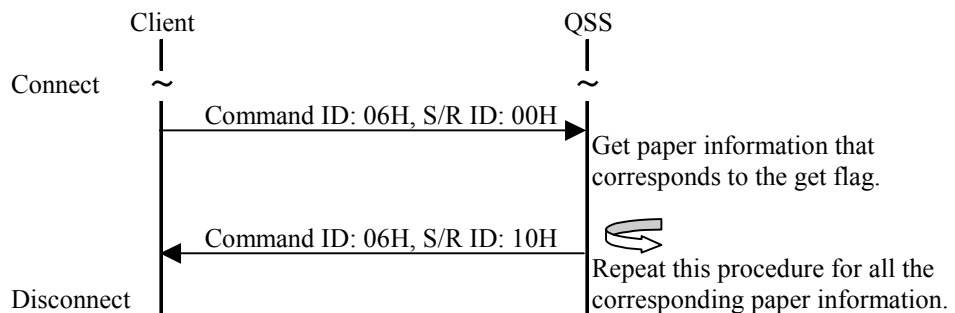

Command ID: 07H (Get error/attention message)

Purpose:

Get error and/or attention message currently occur on QSS.

Send/Receive ID: 00H (Request)

Data division:

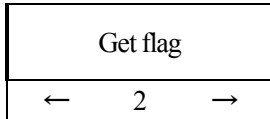

Get flag: (unsigned short)

Defines what information you wish to get from the following:

- 0000 H: Get error related information only
- 0001 H: Get attention message related information only
- 0002 H: Get both error and attention message related information

Send/Receive ID: 10H (Response)

Data division:

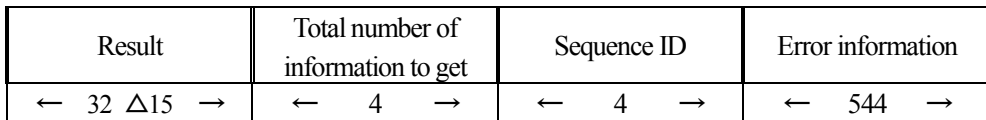

Result:

Refer to [WSQSS_RESULT structure](#).

Total number of information to get: (unsigned long)

Number of error/attention whose information corresponds to the get flag.

QSS will send corresponding error information for each error and attention respectively, so please receive it successively.

NOTE: When there is no corresponding error information, 0 will be defined.

Sequence ID: (unsigned long)

ID is assigned that starts with 1 and increments up to the number of error/attention whose information is to be got.

Error information:

Refer to [WSQSS_ERROR_INFO structure](#).

Communication Sequence:

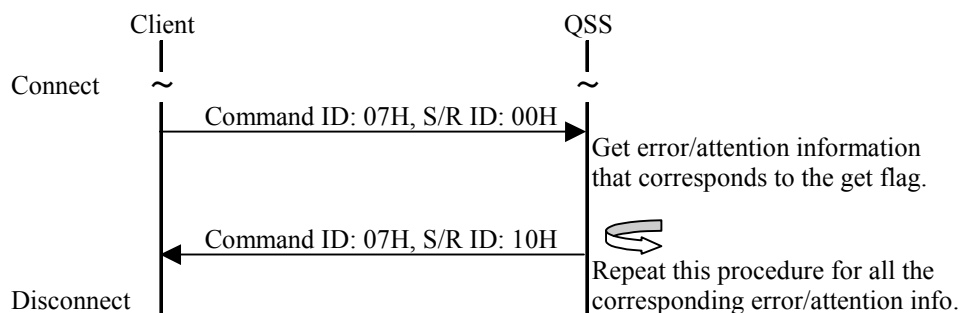

Command ID: 08H (Get order status)

Purpose:

Get the status of the order spooled.

Use this command to confirm the current status of order is either of the following:
Being accepted, Print queue, Printing, Canceling, and Suspended

Send/Receive ID: 00H (Request)

Get status of the order the caller Client has sent to QSS.

Data division:

Client information	Get flag	Request number
← 96 →	← 2 →	← 2 →

Client information:

Refer to [WSQSS_CLIENT_INFO structure](#).

Get flag:

(unsigned short)

Defines which order status you wish to get from the following:

0000H: Get status of the order defined.

0001H: Get status of all the orders that the Client has sent to QSS.

NOTE: You can get the order status of up to 10000 orders.

△4

Request number:

(unsigned short)

Defines the request number of the order whose order status you wish to get.

Valid only when 0000H is defined for get flag.

Send/Receive ID: 10H (Response)

Data division:

Result	Total number of information to get	Sequence ID	Order status information
← 32 △15 →	← 4 →	← 4 →	← 32 →

Result:

Refer to [WSQSS_RESULT structure](#).

Total number of information to get:

(unsigned long)

Number of order whose status information corresponds to the get flag.

QSS will send corresponding order status for each order respectively, so please receive it successively.

NOTE: When there is no corresponding order status information, 0 will be defined.

Sequence ID:

(unsigned long)

ID is assigned that starts with 1 and increments up to the number of order whose information is to be got.

Order status information:

Refer to [WSQSS_ORDER_STATE structure](#).

Communication Sequence:

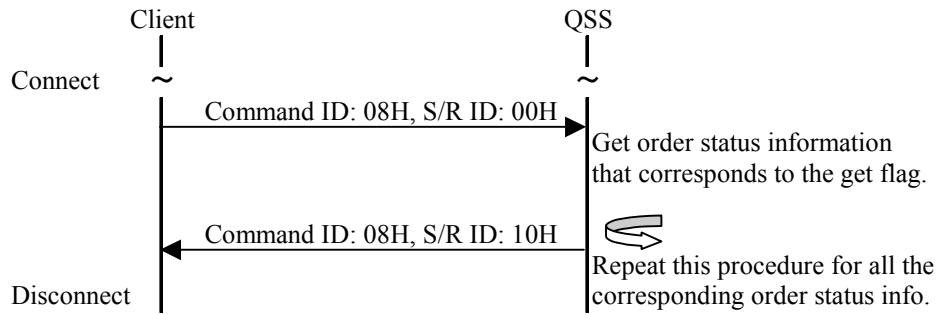

Restrictions

Even though there are more than 10000 orders that have been spooled, you can get the order status of up to 10000 orders.

△4

Command ID: 09H (Get QSS status)

Purpose:

Get current status of QSS.

It is required for Client to call this command to confirm the current status of QSS before sending print request.

Send/Receive ID: 00H (Request)

Data division:

Switch request flag	Reserved
← 2 →	← 32 →

Switch request flag:

(unsigned short)

Defines whether to send request to urge operator to active NetOrder mode or not.

0000 H: Do NOT send request.

0001 H: Send request (so the NetOrder icons blinks on QSS screen).

Reserved:

(unsigned short [16])

Unused

Send/Receive ID: 10H (Response)

Data division:

Result	QSS status
← 32 Δ15 →	← 192 →

Result:

Refer to [WSQSS_RESULT structure](#).

QSS status:

Refer to [WSQSS_PRINTER_STATE structure](#).

Communication Sequence:

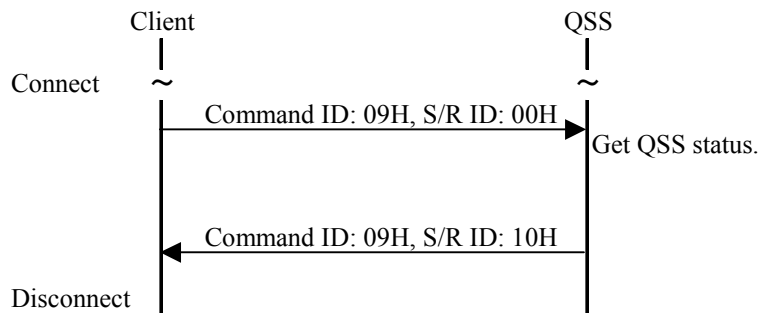

Command ID: 0AH (Get print channel information)

Purpose:

Get print channel information.

Use this command to check the print channel information defined.

Send/Receive ID: 00H (Request)

Data division:

None

Send/Receive ID: 10H (Response)

Data division:

Result	Total number of information to get	Sequence ID	Print channel information
← 32 Δ15 →	← 4 →	← 4 →	← 162 →

Result:

Refer to [WSQSS_RESULT structure](#).

Total number of information to get: (unsigned long)

Number of print channel whose information corresponds to the get flag.

QSS will send corresponding print channel information for each print channel respectively, so please receive it successively.

NOTE: When there is no corresponding print channel information, 0 will be defined.

Sequence ID: (unsigned long)

ID is assigned that starts with 1 and increments up to the number of print channel whose information is to be got.

Print channel information:

Refer to [WSQSS_PRINT_CHANNEL structure](#).

Communication Sequence:

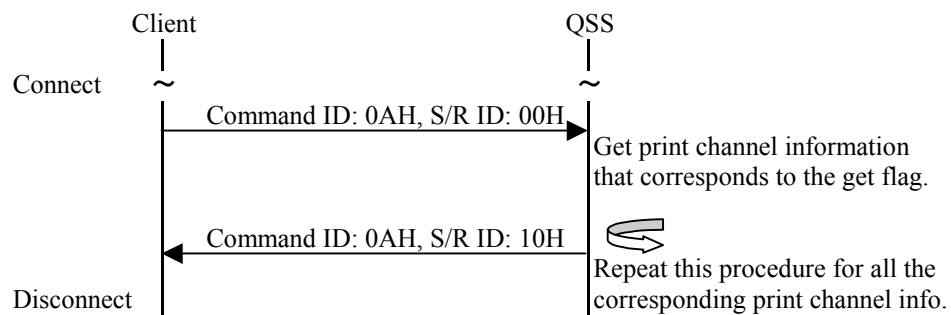

Command ID: 0BH (Get total number of prints or total amount of replenisher solution)

Purpose:

Get total number of prints and/or total amount of replenisher solution of QSS.

Use this command to confirm the total number of print made and/or total amount of replenisher solution consumed on QSS.

Send/Receive ID: 00H (Request)

Data division:

None

Send/Receive ID: 10H (Response)

Data division:

Result	Total information
← 32 Δ15 →	← 1312 →

Result:

Refer to [WSQSS_RESULT structure](#).

Total information:

Refer to [WSQSS_SUM_INFO structure](#).

Communication Sequence:

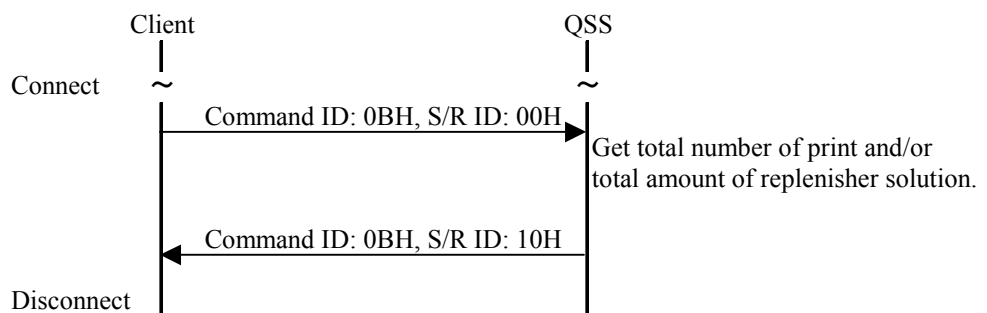

Command ID: 0CH (Get profile information)

Purpose:

Get QSS profile information.

Use this command to get monitor profile and/or printer profile to be used for CMS (Color Management System) of QSS. Printer profile is available for each paper width and surface type.

The profile you get is the ICC (International Color Consortium) profile type of data.

Send/Receive ID: 00H (Request)

Data division:

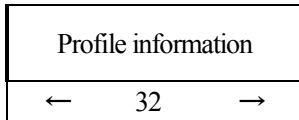

Profile information:

Refer to [WSQSS_PROFILE_INFO structure](#).

Send/Receive ID: 10H (Response)

Data division:

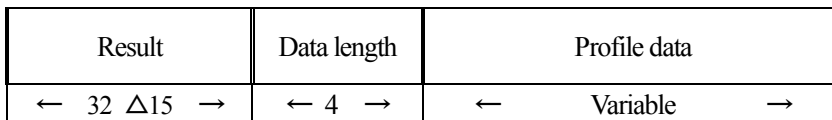

Result:

Refer to [WSQSS_RESULT structure](#).

Data length:

(unsigned long)

Defines the data length of the profile data. (unit: Byte)

Profile data:

Defines profile data.

Communication Sequence:

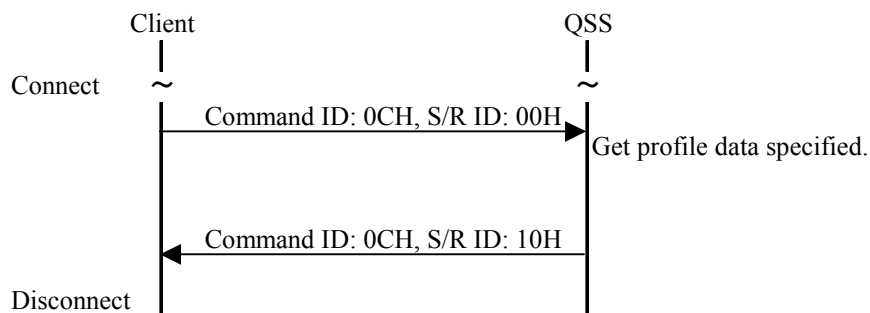

Command ID: 0DH (Cancel order)

Purpose:

Cancel spooled order based on the reference number.

With this command you may delete spooled orders and print data currently in print queue or being printed.

When the order being printed is to be deleted, print interruption process will be performed on QSS first, and then the order will be deleted. Command ID 0DH returns the result to the client without waiting for the completion of print interruption process. Call command ID08H in order to confirm the order is deleted successfully.

Send/Receive ID: 00H (Request)

Data division:

Client information	Reference number
← 96 →	← 8 →

Client information:

Refer to [WSQSS_CLIENT_INFO structure](#).

Reference number (unsigned int64)

Define the reference number of the order to be deleted.

The range is 1 – 999999999999999999 (19 digits).

△6

Send/Receive ID: 10H (Response)

Data division:

Result
← 32 △15 →

Result

Refer to [WSQSS_RESULT structure](#).

Communication Sequence:

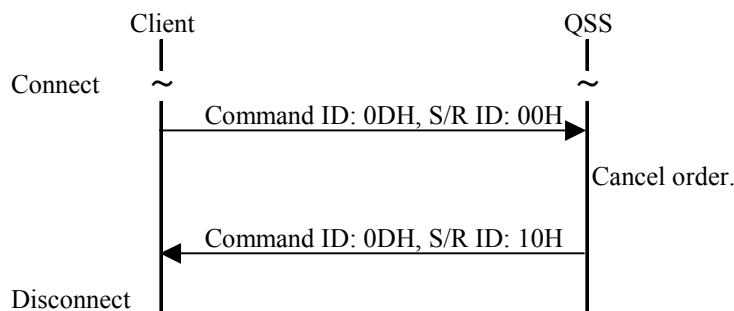

Command ID: 0EH (Get order status) Δ2

Purpose:

Get the current status of the spooled order based on the reference number.

Send/Receive ID: 00H (Request)

Get status of the order the caller Client has sent to QSS.

Data division:

Client information	Get flag	Reference number
← 96 →	← 2 →	← 8 →

Client information:

Refer to [WSQSS_CLIENT_INFO structure](#).

Get flag:

(unsigned short)

Defines which order status you wish to get from the following:

0000H: Get status of the order defined.

0001H: Get status of all the orders that the Client has sent to QSS.

NOTE: You can get the order status of up to 10000 orders.

Δ4

Reference number:

(unsigned short)

Defines the reference number of the order whose order status you wish to get.

Valid only when 0000H is defined for get flag.

Send/Receive ID: 10H (Response)

Data division:

Result	Total number of information to get	Sequence ID	Order status information
← 32 Δ15 →	← 4 →	← 4 →	← 32 →

Result:

Refer to [WSQSS_RESULT structure](#).

Total number of information to get:

(unsigned long)

Number of order whose status information corresponds to the get flag.

QSS will send corresponding order status for each order respectively, so please receive it successively.

NOTE: When there is no corresponding order status information, 0 will be defined.

Sequence ID:

(unsigned long)

ID is assigned that starts with 1 and increments up to the number of order whose information is to be got.

Order status information:

Δ3

Refer to [WSQSS_ORDER_STATE_EX structure](#).

Communication Sequence:

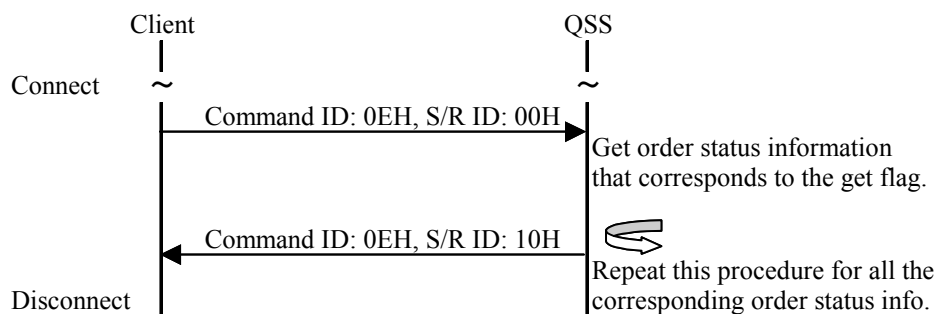

Restrictions

Even though there are more than 10000 orders that have been spooled, you can get the order status of up to 10000 orders.

△4

Command ID: 0FH (Get order history) Δ2

Purpose:

Get order history.

Send/Receive ID: 00H (Request)

Get order history.

Data division:

Client information	Receipt date	Order type
← 96 →	← 10 →	← 2 →

Client information:

Refer to [WSQSS_CLIENT_INFO structure](#).

Receipt date (Mandatory):

(unsigned short)

Define the day when QSS has received the order with [WSQSS_DATETIME structure](#) as a condition to get order history. Year, month, and day must be defined in [WSQSS_DATETIME structure](#).

Order type (Optional):

(unsigned short)

Define the type of order – either printed or canceled order - you wish to get history of as a condition to get order history as follows. When 0 is defined, order history returned will include both types of orders.

Value	Description
QSS_ORDER_STATUS_PRINTED	Printed order
QSS_ORDER_STATUS_CANCELED	Canceled order

Send/Receive ID: 10H (Response)

Data division:

Result	Total number of information to get	Sequence ID	Order history information
← 32 Δ15 →	← 4 →	← 4 →	← 140 →

Result:

Refer to [WSQSS_RESULT structure](#).

Total number of information to get:

(unsigned long)

Number of order that meets the conditions specified in Receipt date and Order type.

QSS will send corresponding order status for each order respectively, so please receive it successively.

NOTE: When there is no corresponding order, 0 will be defined.

Sequence ID:

(unsigned long)

ID is assigned that starts with 1 and increments up to the number of order whose information is to be got.

Order history information:

(unsigned long)

Refer to [WSQSS_ORDER_HISTORY structure](#).

Communication Sequence:

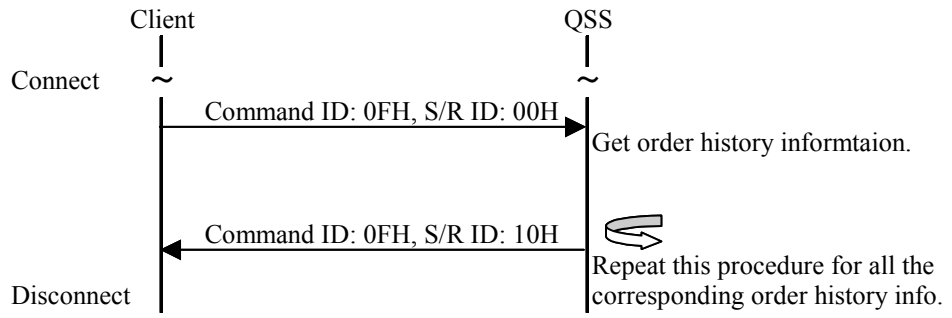

Command ID: 12H (Send print data) Δ9

Purpose:

Send print data to QSS. By the combination of command ID's 12H and 13H Fast Print function will be made available.
 Δ12-2

QSS will start printing upon its receipt of print data as far as it is ready to print. For that purpose, it is required to call command ID 13H to spool the order before sending print data (that consists of image to print and parameter required for printing) to QSS via command ID 12H.

This is not applicable to QSS-28, QSS-29, and QSS-30.

Send/Receive ID: 00H (Request)

Data division:

Client information	Frame print parameter information	Image data
← 96 →	← 384 →	← variable →

Client information:

Refer to [WSQSS_CLIENT_INFO structure](#).

Frame print parameter information

Refer to [WSQSS_FRAME_PARAM2 structure](#).

Image data

Image data to be printed

NOTE: Set the length of the image data to the FileSize in the WSQSS_FRAME_PARAM2 structure.

Send/Receive ID: 10H (Response)

Data division:

Result
← 32 Δ15 →

Result:

Refer to [WSQSS_RESULT structure](#).

Communication Sequence:

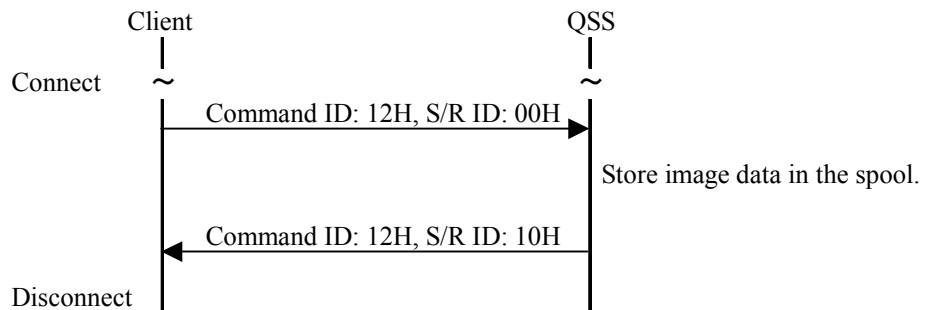

Command ID: 13H (Spool order) Δ9

Purpose:

Spool order. By the combination of command ID's 13H and 12H Fast Print function will be made available. Δ12-3

QSS will start printing upon its receipt of print data as far as it is ready to print. For that purpose, it is required to first call command ID 13H to spool the order and then to call command ID 12H to send the print data (that consists of print image and parameter required for printing) to QSS, to initiate printing.

This is not applicable to QSS-28, QSS-29, and QSS-30.

Send/Receive ID: 00H (Request)

Data division:

Client information	Order print parameter information
← 96 →	← 256 →

Client information:

Refer to [WSQSS_CLIENT_INFO structure](#).

Order print parameter information

Refer to [WSQSS_FRAME_PARAM2 structure](#).

Send/Receive ID: 10H (Response)

Data division:

Result
← 32 Δ15 →

Result:

Refer to [WSQSS_RESULT structure](#).

Communication Sequence:

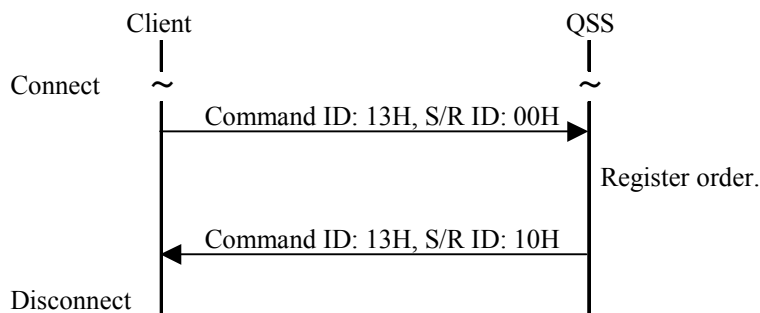

3. Structures to be used for communications

Data alignment is of big endian of network byte order. In case host byte order is of little endian, conversion is required.
 Alignment of structure member is 2 byte.

WSQSS_PRINTER_INFO structure

```
typedef struct _WSQSS_PRINTER_INFO {
    unsigned char    Name[20];
    unsigned long    Version;
    unsigned char    IPAddress[4];
    unsigned short   SystemInfo;
    unsigned char    Reserve[34];
} WSQSS_PRINTER_INFO;
```

Member:

Name	[Output]							
Defines QSS model name. The string should be NULL terminated. e.g. QSS-2801 -> "QSS-28" QSS-2901 -> "QSS-29"								
Version	[Output]							
Defines version of QSS network service. Version number is described in hex. e.g. When QSS network service is of version 1.2.3, 0x01020300 is set.								
IPAddress	[Output]	Δ3						
Defines IP address of QSS.								
SystemInfo	[Output]	Δ20-2						
Defines the running status of the QSS as follows:								
<table border="1" style="width: 100%; border-collapse: collapse;"> <thead> <tr> <th style="text-align: left;">Value</th> <th style="text-align: left;">Description</th> </tr> </thead> <tbody> <tr> <td>QSS_SYSTEM_INFO_QSS</td> <td>Running as QSS</td> </tr> <tr> <td>QSS_SYSTEM_INFO_DDP</td> <td>Running as dDP</td> </tr> </tbody> </table>			Value	Description	QSS_SYSTEM_INFO_QSS	Running as QSS	QSS_SYSTEM_INFO_DDP	Running as dDP
Value	Description							
QSS_SYSTEM_INFO_QSS	Running as QSS							
QSS_SYSTEM_INFO_DDP	Running as dDP							
Reserve								
Unused								

WSQSS_CLIENT_INFO structure

```
typedef struct _WSQSS_CLIENT_INFO {
    unsigned char    User[20];
    unsigned char    Host[20];
    unsigned char    Address[6];
    unsigned char    IPAddress[4];
    unsigned short   Port;
    unsigned long    Version;
    unsigned short   Level;
    unsigned char    Reserve[38];
} WSQSS_CLIENT_INFO;
```

Member:

User	[Input]	
Define user name.		
The string should be a maximum of 19 characters and NULL terminated.		
Host	[Input]	
Define host name.		
The string should be a maximum of 19 characters and NULL terminated.		
Address	[Input]	
Define MAC address.		
IPAddress	[Input]	△2
Define IP address of Client host PC.		
Port	[Input]	
Define port number of the socket to receive event notification.		
Version	[Input]	
Define version of NetOrder API to use.		
Level	[Input]	
Define Client level.		
<hr/>		
Value	Description	
QSS_CLIENT_LEVEL1	Status of orders that the Client has sent to QSS is received in order status notification from QSS.	
QSS_CLIENT_LEVEL2	Status of all orders is received in order status notification from QSS.	
Reserve		
Unused		

Remarks:

Used as the information when QSS manages and controls orders.
 This structure serves as an authentication when canceling an order that has been accepted and as identifier when checking the order from the order management screen of QSS.

WSQSS_FRAME_PARAM structure

```
typedef struct _WSQSS_FRAME_PARAM {
    unsigned short    OrderNo;
    unsigned short    FrameNum;
    unsigned short    FrameNo;
    unsigned char     FileName[18];
    unsigned long     FileSize;
    unsigned long     ImageFormat;
    unsigned short    PrintSize;
    unsigned short    RepeatNum;
    unsigned short    RepeatPos;
    unsigned char     CvpString1[120];
    unsigned char     CvpString2[120];
    unsigned short    CvpFlg;
    unsigned short    PaperWidth;           // Version 1.0.4           △1
    unsigned short    PaperLength;         // Version 1.0.5           △3
    unsigned short    Surface;             // Version 1.0.4           △1
    unsigned short    WithBorder;         △24-1
};
```

```

unsigned short    PaperFittingFlg;                                Δ24-2
unsigned short    ImageXPixels;                                // (Unused)
unsigned short    ImageYPixels;                                // (Unused)
unsigned short    Reserve1;                                    // (Unused)
unsigned_int64    RefId;                                        // Version 1.0.4                Δ1
unsigned short    SizeRate;                                    // (Unused)
unsigned short    Rotate;                                      // (Unused)
short             CenterX;                                      // (Unused)
short             CenterY;                                      // (Unused)
unsigned char     Way;                                        // (Unused)                                Δ24-3
unsigned char     Reserve2;                                    // (Unused)                                Δ24-4
unsigned short    EnablePaperFittingFlg;                       Δ24-5
unsigned char     Reserve[4];
} WSQSS_FRAME_PARAM;

```

Member:

OrderNo [Input]
 Request number
 The range is 0 – 65535. When 65535 (0xFFFF) is defined, an order will be added using the reference number as the administration key. Δ6

FrameNum [Input]
 Define the total number of frames an order consists of.
 The range is 1 to 999.

FrameNo [Input]
 Define frame number.
 The range is 1 to 999.

FileName [Input]
 Define the file name of the image to be sent to QSS.
 (Mainly used for index.)
 The string should be a maximum of 17 characters and NULL terminated.

FileSize [Input]
 Define the file size of the image to be sent to QSS. (unit: Byte)

ImageFormat [Input]
 Define the format of the image to be sent to QSS.
 Define one of the formats defined in SupportImageFormat of QSS_PRINTER_STATE structure by calling QssGetPrinterState function.
 You may define any image format to each individual frame.

PrintSize [Input]
 Define print size as follows: Δ3

Value	Description
QSS_PRINT_SIZE_C	Values of PaperWidth, PaperLengthC, Surface, and WithBorderC of WSQSS_ORDER_PARAM structure are adopted.
QSS_PRINT_SIZE_P	Values of PaperWidth, PaperLengthP, Surface, and WithBorderP of WSQSS_ORDER_PARAM structure are adopted.
QSS_PRINT_SIZE_H	Values of PaperWidth, PaperLengthH, Surface, and WithBorderH of WSQSS_ORDER_PARAM structure are adopted.
QSS_PRINT_SIZE_FREE_C	Values of PaperWidth, PaperLength, and Surface of this structure and value of WithBorderC of WSQSS_ORDER_PARAM structure are adopted.
QSS_PRINT_SIZE_FREE_P	Values of PaperWidth, PaperLength, and Surface of this structure and value of WithBorderP of WSQSS_ORDER_PARAM structure are adopted.
QSS_PRINT_SIZE_FREE_H	Values of PaperWidth, PaperLength, and Surface of this structure and

value of WithBorderH of WSQSS_ORDER_PARAM structure are adopted.

RepeatNum [Input]

Define the number of repeat print to be made.

The range is 0 to 999.

NOTE: When you define 0, the frame will not be printed but included in index print.

RepeatPos [Input]

Define the position where repeat count (serial number) is printed as part of CVP (Correction Value Print).

0 to 117: 1st line of CVP

120 to 237: 2nd line of CVP

255: No repeat count number included in CVP.

CvpString1 [Input]

CvpString2 [Input]

Define the string to be printed as CVP.

CvpString1: String to be printed on the 1st line of CVP

CvpString2: String to be printed on the 2nd line of CVP

Set arbitrary Noritsu Character Code. The strings must be NULL terminated.

The strings are a maximum of 115 characters, but the number of characters actually printed as CVP depends on the QSS model to be used and the advance length of the print.

When a setting is made with RepeatPos so the repeat count is printed as part of CVP, the values of repeat count (3 characters) will supersede the information that is supposed to be printed in the predetermined position where the values of repeat count are printed. Δ12-4

CvpFlg [Input]

Define whether the values for CVP will be the ones defined by QSS or in CvpString1 and CvpString2.

Value	Description
QSS_CVP_AUX	Values defined in CvpString1 and CvpString2 are printed as the 1 st and 2 nd lines of CVP.
QSS_CVP_1QSS2AUX	Value defined with QSS is printed for the 1 st line, and the one defined in CvpString2 is used for the 2 nd line.
QSS_CVP_1AUX2QSS	Value defined in CvpString1 is printed for the 1 st line, and the one defined with QSS is used for the 2 nd line.
QSS_CVP_QSS	Values defined with QSS are printed as the 1 st and 2 nd lines of CVP.

PaperWidth [Input]

Define width of the paper to be printed. (unit: 1/10mm)

You may define the same number of paper width as that can be installed to the connected QSS.

In case of QSS-31, you may define 2 different paper widths for an order.

In order to use this parameter, be sure to set QSS_PRINT_SIZE_FREE_C, QSS_PRINT_SIZE_FREE_P, or

QSS_PRINT_SIZE_FREE_H in PrintSize. Δ3

PaperLength [Input] Δ1

Define the paper advance length for each frame (unit: 1/10 mm).

When converting the paper width/length from inch to 1/10mm, please refer to “inch – 1/10mm Conversion Table” enclosed in this document.

In order to use this parameter, be sure to set QSS_PRINT_SIZE_FREE_C, QSS_PRINT_SIZE_FREE_P, or

QSS_PRINT_SIZE_FREE_H in PrintSize. Δ3

Surface [Input] Δ1

Define the surface type of the paper to be printed. The range is 1 to 4.

In order to use this parameter, be sure to set QSS_PRINT_SIZE_FREE_C, QSS_PRINT_SIZE_FREE_P, or

QSS_PRINT_SIZE_FREE_H in PrintSize. Δ3

WithBorder [Input] Δ24-6

Define the width of the white border on the resultant print. (unit: 1/10 mm)

The range is 0 – 99.

PaperFittingFlg	[Input]	△24-7
Define the paper fitting. For detail, refer to PaperFitSW of WSQSS_PRINT_CHANNEL structure .		
ImageXPixels		
Unused		
ImageYPixels		
Unused		
Reserve1		
Unused		
RefId	[Input]	
Reference number		
You may define any 64-bit identifier. Setting 0xFFFF to Request number (Order No) enables to add an order based on the reference number.		
This also enables to use 64-bit data as administration key in case client manages orders. You may input any number between 1 and 999999999999999999 (19 digits).		
SizeRate		
Unused		
Rotate		
Unused		
CenterX		
Unused		
CenterY		
Unused		
Way		△24-8
Unused		
Reserve2		△24-9
Unused		
EnablePaperFittingFlg	[Input]	△24-10
Set "0" in order not to use the paper fitting on a frame basis (PaperFittingFlag); otherwise set 1.		
Reserve		
Unused		

WSQSS_ORDER_PARAM structure

```
typedef struct _WSQSS_ORDER_PARAM {
    unsigned short    OrderNo;
    unsigned short    FrameNum;
    unsigned short    PaperWidth;
    unsigned short    PaperLengthC;
    unsigned short    PaperLengthP;
    unsigned short    PaperLengthH;
    unsigned short    Surface;
    unsigned short    WithBorderC;
    unsigned short    WithBorderP;
    unsigned short    WithBorderH;
    unsigned short    IndexPrintFlg;
    unsigned short    PaperFittingFlg;
    unsigned short    IndexPaperWidth;
    unsigned short    IndexSurface;
    unsigned short    CmsFlg;
    unsigned short    Reserve1;           //(Unused)
}
```

```

unsigned_int64      RefId;                // Version 1.0. 4          Δ1
unsigned short     SorterNum;            // Version 1.0.6          Δ5
unsigned char      Reserve[24];
} WSQSS_ORDER_PARAM;

```

Member:

OrderNo [Input]
 Define request number.
 The range is 0 – 65535. When 65535 (0xFFFF) is defined, an order will be added using the reference number as the administration key. Δ6

FrameNum [Input]
 Define total number of frames an order consists of.
 The range is 1 to 999.

PaperWidth [Input]
 Define width of the paper to be printed. (unit: 1/10mm)

PaperLengthC [Input]

PaperLengthP [Input]

PaperLengthH [Input]

Define advance length of the paper. (unit: 1/10mm)
 PaperLengthC: Define paper advance length for Classical size print.
 PaperLengthP: Define paper advance length for Panoramic size print.
 PaperLengthH: Define paper advance length for High-definition size print
 Be sure to define paper length that falls between the minimum and maximum paper lengths (PaperLengthMin and PaperLengthMax) of the paper information (WSQSS_PAPER_INFO). Δ15-3

Surface [Input]
 Define the surface type of the paper to be printed.
 The range is 1 to 4.

WithBorderC [Input]

WithBorderP [Input]

WithBorderH [Input]

Define the width of the white boarder of the resultant print (range: 0-99, unit: 1/10mm)
 When you define 0, resultant print will have no border.
 WithBorderC: Define the width of white boarder for Classical size print.
 WithBorderP: Define the width of white boarder for Panoramic size print.
 WithBorderH: Define the width of white boarder for High-definition size print.

IndexPrintFlg [Input]

Define the page size of index print from the following: Δ11-4

Value	Index size	X: Support, -: Not support					
		28xx	29xx 30xx 31xx (except 3102-2)	3102-2	32xx 34xx	3300	33
QSS_INDEX_NONE	No index print	X	X	X	X	X	X
QSS_INDEX_3HS	3HS (82.5mm x 158mm)	X	X	X	X	X	X
QSS_INDEX_3R	3R (89mm x 127mm)	X	X	X	X	X	X
QSS_INDEX_3HD	3HD (89mm x 158mm)	X	X	X	X	X	X
QSS_INDEX_3W	3W (89mm x 178mm)	-	-	-	-	-	-
QSS_INDEX_3WS	3WS (89mm x 178mm)	X	X	X	X	X	X
QSS_INDEX_4R	4R (102mm x 152mm)	X	X	X	X	X	X
QSS_INDEX_4HD	4HD (102mm x 178mm)	X	X	X	X	X	X

QSS_INDEX_5R	5R (127mm x 178mm)	X	X	X	X	X	X
QSS_INDEX_6R	6R (152mm x 203mm)	X	X	X	X	X	X
QSS_INDEX_6HD	6HD (152mm x 254mm)	X	X	X	X	X	X
QSS_INDEX_6W	6W (152mm x 305mm)	X	X	X	X	X	X
QSS_INDEX_8RS	8RS (203mm x 254mm)	-	X	X	X	X	X
QSS_INDEX_8R	8R (203mm x 305mm)	-	X	X	X	X	X
QSS_INDEX_8HD	8HD (203mm x 356mm)	-	X	X	X	X	X
QSS_INDEX_CD40	CD_40 (120mm x 120mm)	-	X	X	X	X	X
QSS_INDEX_CD40A	CD_40A (89mm x 120mm)	-	X	X	X	X	X
QSS_INDEX_CD40B	CD_40B (102mm x 120mm)	-	X	X	X	X	X
QSS_INDEX_3WL	3WL (89mm x 254mm)	-	X	X	X	X	X
QSS_INDEX_3WL_18	3WL_18 (89mm x 254mm)	-	X	X	X	X	X
QSS_INDEX_4WL_18	4WL_18 (102mm x 254mm)	-	X	X	X	X	X
QSS_INDEX_12R	12R (305mm x 457mm)	-	-	X	X	-	-
△13-1							

Number of frames to be printed on an index print will be calculated automatically based on the size of the index print to be made and the number of frames included in the order.

IndexPrintFlg

[Input]

Define the page size of index print from the following:

Value	Index size	X: Support, -: Not support			
		QSS-28	QSS-29	QSS-30	QSS-31
QSS_INDEX_NONE	No index print	X	X	X	X
QSS_INDEX_3HS	3HS (82.5mm x 158mm)	X	X	X	X
QSS_INDEX_3R	3R (89mm x 127mm)	X	X	X	X
QSS_INDEX_3HD	3HD (89mm x 158mm)	X	X	X	X
QSS_INDEX_3W	3W (89mm x 178mm)	-	-	-	-
QSS_INDEX_3WS	3WS (89mm x 178mm)	X	X	X	X
QSS_INDEX_4R	4R (102mm x 152mm)	X	X	X	X
QSS_INDEX_4HD	4HD (102mm x 178mm)	X	X	X	X
QSS_INDEX_5R	5R (127mm x 178mm)	X	X	X	X
QSS_INDEX_6R	6R (152mm x 203mm)	X	X	X	X
QSS_INDEX_6HD	6HD (152mm x 254mm)	X	X	X	X
QSS_INDEX_6W	6W (152mm x 305mm)	X	X	X	X
QSS_INDEX_8RS	8RS (203mm x 254mm)	-	X	X	X
QSS_INDEX_8R	8R (203mm x 305mm)	-	X	X	X
QSS_INDEX_8HD	8HD (203mm x 356mm)	-	X	X	X

Number of frames to be printed on an index print will be calculated based on the size of the index print to be made and the number of frames included in the order.

CmsFlg

[Input]

Define whether or not to apply QSS CMS to the received order as follows:

Value	Description
QSS_CMS_ON	CMS conversion is performed by QSS.
QSS_CMS_OFF	CMS conversion is NOT performed by QSS.

Reserve1

Unused.

RefId

[Input]

Reference number.

You may define any 64-bit identifier. Setting 0xFFFF to Request number (Order No) enables to add an order based on the reference number.

This also enables to use 64-bit data as administration key in case Client manages orders. You may input any number between 1 and 999999999999999999 (19 digits).

SorterNum

[Input]

△5

You may define how many prints are placed on a receiver of the sorter before sorter moves.

The range is 0 – 120.

When you define 0, the sorter will move when the maximum number of prints that a receiver can hold is placed on a receiver.

SorterNum is available with the NetOrder API of version 1.0.6 or up.

With earlier version of NetOrder API, this value is fixed to 0.

Client is requested to set the version of the NetOrder API that it uses to Version of QSS_CLIENT_INFO.

When the version in use is 1.0.6, set 0x01000600 to Version.

This is not available with QSS-30.

△7

Reserve

Unused

Remarks:

For PaperWidth, Surface, IndexPaperWidth, and IndexSurface, define the value of the paper that has been registered on QSS.

You may get information on the registered paper by using command ID 06H.

NOTE:

In case of single-magazine type QSS, paper must be consistent between normal print (PaperWidth and Surface) and index print (IndexPaperWidth and Index Surface).

WSQSS_PAPER_INFO structure

```
typedef struct _WSQSS_PAPER_INFO {
    unsigned short    PaperWidth;
    unsigned short    Resolut;
    unsigned short    MagazineState;
    unsigned long     PaperRemaind;
    unsigned short    Surface;
    unsigned short    PaperLengthMin;
    unsigned short    PaperLengthMax;
    unsigned char     Reserve[48];
} WSQSS_PAPER_INFO;
```

Member:

PaperWidth [Output]

Defines the paper width. (unit: 1/10mm)

Resolut [Output]

Defines the printing resolution. (unit: 1/10dpi)

MagazineState: [Output]

Defines the presence of paper magazine.

Value	Description
QSS_MAGAZINE_NONE	No paper magazine installed.
QSS_MAGAZINE_A	Paper magazine is installed on magazine A.
QSS_MAGAZINE_B	Paper magazine is installed on magazine B.
QSS_MAGAZINE_C △7	Paper magazine is installed on magazine C.
QSS_MAGAZINE_A2 △25-1	Paper magazine is installed on magazine A2.

PaperRemaind [Output]

Defines the length of remaining paper. (unit: 1/10mm)

Note that “0” is defined for QSS_MAGAZINE_NONE. △25-2

Surface [Output]

Defines paper surface.

The range is 1 to 4.

PaperLengthMin	[Output]
PaperLengthMax	[Output]
Defines the range of paper advance length that you may specify. (unit: 1/10mm)	
PaperLengthMin: Define the minimum advance length you may specify.	
PaperLengthMax: Define the maximum advance length you may specify.	
Reserve	[Output]
Unused	

WSQSS_ERROR_INFO structure

```
typedef struct _WSQSS_ERROR_INFO {
    unsigned short    MainNo;
    unsigned short    SubNo;
    unsigned short    Level;
    wchar_t           Message[256];
    unsigned char     Reserve[26];
} WSQSS_ERROR_INFO;
```

Member:

MainNo	[Output]
Defines the error/attention number that currently occurs on QSS.	
The range is 1 to 9999, where 1 to 4999 are for attention messages and 5000 to 9999 are for errors.	
SubNo	[Output]
Defines suffix of error number.	
Level	[Output]
Defines error level as follows:	

Value	Description
QSS_ERROR_LVL1	Error that operator can address easily
QSS_ERROR_LVL2	Error that needs investigation of the cause and sometimes even needs to call service personnel, such as temperature related error
QSS_ERROR_LVL3	Error that needs to call service personnel, such as PCB malfunction

Message	[Output]
Defines the error message.	
Language of message to be defined will be consistent to language specified on QSS.	
Reserve	[Output]
Unused	

WSQSS_ORDER_STATE structure

```
typedef struct _WSQSS_ORDER_STATE {
    unsigned short    OrderNo;
    unsigned short    OrderState;
    unsigned short    Reserve1[2]; // (Unused) Δ1 Δ3
    unsigned hyper    RefId; // Version 1.0.4 Δ1 Δ3
    WSQSS_DATETIME   FinishTime; Δ19-1
    unsigned char     Reserve[18];
} WSQSS_ORDER_STATE;
```

Member:

OrderNo	[Input][Output]	
Request number		
The range is 0 – 65534.		△6
OrderState	[Output]	
Defines the order status as follows:		
<hr/>		
Value	Description	
QSS_ORDER_ACCEPT	Being accepted	
QSS_ORDER_WAIT	Print queue	
QSS_ORDER_PRINT	Printing	
QSS_ORDER_CANCEL	Canceling	
QSS_ORDER_RESERVE	Suspended	
QSS_ORDER_PRINTED	Finished	△2
QSS_ORDER_CANCELED	Canceled	
QSS_ORDER_NONE	No order	
Reserve1		△1 △3
Unused		
RefId	[Output]	△1 △3
Reference number:		
FinishTime	[Output]	△19-2
Defines the estimated finish time of the order.		
Reserve		
Unused		

WSQSS_ORDER_STATE_EX structure △3

```
typedef struct _WSQSS_ORDER_STATE {
    unsigned short    OrderNo;
    unsigned short    OrderState;
    unsigned short    Reserve1[2];
    unsigned hyper    RefId;
    WSQSS_DATETIME   FinishTime;
    unsigned char     Reserve[6];
} WSQSS_ORDER_STATE;
```

Member:

OrderNo	[Output]	
Request number		
OrderState	[Output]	
Defines the order status as follows:		
<hr/>		
Value	Description	
QSS_ORDER_ACCEPT	Being accepted	
QSS_ORDER_WAIT	Print queue	
QSS_ORDER_PRINT	Printing	
QSS_ORDER_CANCEL	Canceling	
QSS_ORDER_RESERVE	Suspended	
QSS_ORDER_PRINTED	Finished	
QSS_ORDER_CANCELED	Canceled	
QSS_ORDER_NONE	No order	
Reserve1		

Unused.		
RefId	[Input][Output]	
Reference number.		
The range is 1 – 999999999999999999 (19 digits).		△6
Reserve		
Unused		

WSQSS_PRINTER_STATE structure

```
typedef struct _WSQSS_PRINTER_STATE {
    unsigned short      QssState;
    unsigned short      AbleReceive;
    unsigned short      AblePU;
    WSQSS_PAPER_INFO    MagazineA;
    WSQSS_PAPER_INFO    MagazineB;
    unsigned long        SupportImageFormat;
    UnsignedWide         TotalPrintNum;
    unsigned short       TemperatureCD;
    unsigned short       TemperatureBF;
    unsigned short       TemperatureSTB;
    unsigned short       RemaindQuantityCD;
    unsigned short       RemaindQuantityBF;
    unsigned short       RemaindQuantitySTB;
    unsigned hyper       SpoolerSpace;
    unsigned short       IsNetOrderMode;
    unsigned short       IsCalibrationMode;
    unsigned short       EnableOutMediaViewer;
    unsigned char        Reserve[20];
} WSQSS_PRINTER_STATE;
```

Member:

QssState [Output]

Defines the QSS status as follows:

Value	Description
QSS_STATE_PRINT	Printing
QSS_STATE_SETUP	Being adjusted (temperature being adjusted, maintenance screen being displayed, etc.)
QSS_STATE_IDLE	Idling
QSS_STATE_ALERT	Error/Attention message is given.

AbleReceive [Output]

Defines whether the input from an external source is printable or not on QSS.

Value	Description
QSS_RECEIVE_ENABLE	Printable
QSS_RECEIVE_DISABLE	Not printable

AblePU [Output]

Defines whether PU connected to QSS is enabled or not.

Value	Description
QSS_PU_ENABLE	Enabled
QSS_PU_DISABLE	Disabled

MagazineA [Output]

MagazineB [Output]

Defines the information on the paper magazine installed on QSS.

MagazineA: Magazine A

MagazineB: Magazine B

SupportImageFormat [Output]

Defines the image format that QSS supports.

Bit assignment of image format is as follows (Bit 1: Support, 0: Not support):

(There are cases where multiple formats are selected.)

0: JPEG	8: Filmstrip	16: Photo CD	24: Unused
1: BMP	9: FlashPix	17: Photoshop doc	25: Unused
2: RGB raw	10: PCX	18: Unused	26: Unused
3: RGB raw (16Bit)	11: PICT	19: Unused	27: Unused
4: GIF	12: Pixar	20: Unused	28: Unused
5: TIFF	13: PNG	21: Unused	29: Unused
6: Amiga IFF	14: Scitex CT	22: Unused	30: Unused
7: EPS	15: Targa	23: Unused	31: Unused

e.g.) When QSS supports both JPEG and BMP, the bit assignment will be as follows, and the variable is “3” in decadal system.

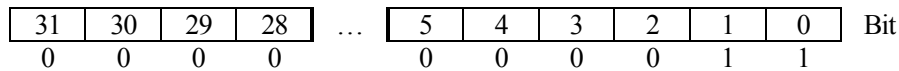

TotalPrintNum [Output]

Defines the total number of prints of the order currently being printed or printed last.

Number of index print is not included.

TemperatureCD [Output]

TemperatureBF [Output]

TemperatureSTB [Output]

Defines the current temperature of each processing solution (unit: 0.01 deg C)

TemperatureCD: Define the temperature of CD

TemperatureBF: Define the temperature of BF

TemperatureSTB: Define the temperature of STB

RemaindQuantityCD [Output]

RemaindQuantityBF [Output]

RemaindQuantitySTB [Output]

Unused

SpoolerSpace [Output]

Defines the free space for the spool. (unit: Byte)

IsNetOrderMode [Output] △13-3

A flag is set to determine whether QSS is currently in the NetOrder mode or not.

Value	Description
QSS_NETORDER_ON	QSS is in NetOrder mode.
QSS_NETORDER_OFF	QSS is not in NetOrder mode.

IsCalibrationMode [Output] △13-4

A flag is set to determine whether the NetOrder is currently in the calibration mode or not.

Value	Description
QSS_CALIBRAT_ON	NetOrder is in the calibration mode.
QSS_CALIBRAT_OFF	NetOrder is not in the calibration mode.

EnableOutMediaViewer [Output] △20-4

Available type of viewer is defined with bit allocation.

Value	Description
QSS_MEDIA_VIEWER_QSS	Comply with QSS setting
QSS_MEDIA_VIEWER_NONE	No Viewer

QSS_MEDIA_VIEWER_SIMPLE	Simple Viewer
QSS_MEDIA_VIEWER_DELUXE	Deluxe Viewer
QSS_MEDIA_VIEWER_PICTURECD_5	Picture CD Vol. 5 or earlier
QSS_MEDIA_VIEWER_PICTURECD_6	Picture CD Vol. 6 or forward

Reserve

Unused

WSQSS_PRINT_CHANNEL structure

```
typedef struct _WSQSS_PRINT_CHANNEL {
    short          ChNo;
    unsigned short Meishou[11];
    short          Printtype;
    unsigned char  InpMediaType;
    unsigned short MeishouCph[3][6];
    short          Haba[3];
    short          Mensitu[3];
    short          Feed[3];
    short          WbHaba[3];
    short          SizeRate[3];
    short          RokouichiHosei[3];
    short          CvpSw;
    short          FPSw;
    short          IDPSize[3];
    short          IndexHaba[3];
    short          IndexMensitu[3];
    unsigned char  OutMediaSw;
    unsigned short OutMediaFormat;
    unsigned char  OutMediaInfoQuality;
    unsigned char  OutMediaInfoQualityPer;
    unsigned char  OutMediaInfoSize;
    unsigned char  PaperFitSW;
    unsigned short EditModeNo;
    unsigned short Template;
    unsigned char  PapScan120;
    unsigned char  Reserve[27];
} WSQSS_PRINT_CHANNEL;
```

Member:

- ChNo [Output]
Defines the channel number.
- Meishou [Output]
Defines the channel name.
- Printtype [Output]
Defines the type of print as follows:

Value	Description
QSS_PRINTTYPE_NONE	Undefined
QSS_PRINTTYPE_NORMAL	Normal print
QSS_PRINTTYPE_EDIT	Edit print
QSS_PRINTTYPE_PACKAGE	Package print

QSS_PRINTTYPE_ALBUM	Album
QSS_PRINTTYPE_LONG Δ7	Long length print

InpMediaType

[Output]

Defines the type of input media as follows:

Value	Description
QSS_INPMEDIA_NONE	Undefined
QSS_INPMEDIA_CL_NEGA	Color negative
QSS_INPMEDIA_BW_NEGA	Black and white negative
QSS_INPMEDIA_CL_POSI	Color positive
QSS_INPMEDIA_BW_POSI	Black and white positive
QSS_INPMEDIA_PRN_PHOTO	Capture image
QSS_INPMEDIA_MO	MO
QSS_INPMEDIA_FD	FD
QSS_INPMEDIA_DVD	DVD
QSS_INPMEDIA_CD	CD
QSS_INPMEDIA_ZIP	ZIP
QSS_INPMEDIA_SM	Smart Media
QSS_INPMEDIA_CF	Compact Flash
QSS_INPMEDIA_PCCARD	PC Card
QSS_INPMEDIA_HD	HD
QSS_INPMEDIA_SEPIA	Sepia
QSS_INPMEDIA_BW_OB	Monochrome negative (Orange base)
QSS_INPMEDIA_CTERM Δ7	C Terminal
QSS_INPMEDIA_RDS Δ7	RDS
QSS_INPMEDIA_SD Δ7	SD Card
QSS_INPMEDIA_MS Δ7	Memory Stick
QSS_INPMEDIA_STORAGE Δ7	d-Storage
QSS_INPMEDIA_USB Δ7	USB Flash Memory
QSS_INPMEDIA_XD_CARD Δ12-5	xD-Picture Card
QSS_INPMEDIA_MINI_SD Δ12-6	miniSD Card
QSS_INPMEDIA_MS_DUO Δ12-7	Memory Stick Duo
QSS_INPMEDIA_DVD_ROM Δ16-1	DVD+/-R/RW

MeishouCph

[Output]

Defines the print name for each type of print.

From the head of the array, Classical, Panoramic, and High-definition sizes are defined.

Haba

[Output]

Defines the width of the print for each type of print. (unit: 1/10 mm)

From the head of the array, Classical, Panoramic, and High-definition sizes are defined.

Mensitu

[Output]

Defines the type of paper surface for each type of print.

From the head of the array, Classical, Panoramic, and High-definition sizes are defined.

Feed

[Output]

Defines the advance length of paper for each type of print. (unit: 1/10 mm)

From the head of the array, Classical, Panoramic, and High-definition sizes are defined.

WbHaba

[Output]

Defines the width of the white border for each type of print. (unit: 1/10 mm)

From the head of the array, Classical, Panoramic, and High-definition sizes are defined.

SizeRate

[Output]

Defines the magnification ratio of the image for each type of print. (unit: %)

From the head of the array, Classical, Panoramic, and High-definition sizes are defined.

RokouichiHosei

[Output]

Defines the exposure position correction for each type of print. (unit: 1/10 mm)

From the head of the array, Classical, Panoramic, and High-definition sizes are defined.

CvpSw

[Output]

Defines CVP printing flag as follows:

Value	Description
QSS_CVP_OFF	CVP disabled
QSS_CVP_ON	CVP enabled

FPSw

[Output]

Defines the front print position as follows:

Value	Description
QSS_FP_NONE	Front print will not be made.
QSS_FP_RIGHT	Front print, right justified.
QSS_FP_LEFT	Front print, left justified
QSS_FP_CENTER	Front print, center justified

IDPSize

[Output]

Defines the type of index print as follows:

From the head of the array, 135 film, 240 film, and storage media are defined.

Value	Description
QSS_INDEX_4R	4R (102mm x 152mm) index print
QSS_INDEX_3HD	3HD (89mm x 158mm) index print
QSS_INDEX_3R	3R (89mm x 127mm) index print
QSS_INDEX_4HD	4HD (102mm x 178mm) index print
QSS_INDEX_3W	3W (89mm x 178mm) index print
QSS_INDEX_5R	5R (127mm x 178mm) index print
QSS_INDEX_3WS	3WS (89mm x 178mm) index print
QSS_INDEX_3HS	3HS (82.5mm x 158mm) index print
QSS_INDEX_6R	6R (152mm x 203mm) index print
QSS_INDEX_6HD	6HD (152mm x 254mm) index print
QSS_INDEX_6W	6W (152mm x 305mm) index print
QSS_INDEX_8RS	8RS (203mm x 254mm) index print
QSS_INDEX_8R	8R (203mm x 305mm) index print
QSS_INDEX_8HD	8HD (203mm x 356mm) index print
QSS_INDEX_CD40 Δ7	CD_40 (120mm x 120mm) index print
QSS_INDEX_CD40A Δ7	CD_40A (89mm x 120mm) index print
QSS_INDEX_CD40B Δ7	CD_40B (102mm x 120mm) index print
QSS_INDEX_3WL Δ7	3WL (89mm x 254mm) index print
QSS_INDEX_3WL_18 Δ7	3WL_18 (89mm x 254mm) index print
QSS_INDEX_4WL_18 Δ8	4WL_18 (102mm x 254mm) index print
QSS_INDEX_12R Δ13-2	12R (305mm x 457mm) index print
QSS_INDEX_CP6_1	Contact index print of 6 x 1 frames
QSS_INDEX_CP6_2	Contact index print of 6 x 2 frames
QSS_INDEX_CP6_3	Contact index print of 6 x 3 frames
QSS_INDEX_CP6_4	Contact index print of 6 x 4 frames
QSS_INDEX_CP6_5	Contact index print of 6 x 5 frames
QSS_INDEX_CP6_6	Contact index print of 6 x 6 frames
QSS_INDEX_CP6_7	Contact index print of 6 x 7 frames
QSS_INDEX_CP4_1	Contact index print of 4 x 1 frames
QSS_INDEX_CP4_2	Contact index print of 4 x 2 frames
QSS_INDEX_CP4_3	Contact index print of 4 x 3 frames
QSS_INDEX_CP4_4	Contact index print of 4 x 4 frames

QSS_INDEX_CP4_5	Contact index print of 4 x 5 frames
QSS_INDEX_CP4_6	Contact index print of 4 x 6 frames
QSS_INDEX_CP4_7	Contact index print of 4 x 7 frames
QSS_INDEX_CP4_8	Contact index print of 4 x 8 frames
QSS_INDEX_CP4_9	Contact index print of 4 x 9 frames
QSS_INDEX_CP4_10	Contact index print of 4 x 10 frames

IndexHaba [Output]

Defines the paper width of index print. (unit: 1/10 mm)
From the head of the array, 135 film, 240 film, and storage media are defined.

IndexMensitu [Output]

Defines the paper surface of index print.
The range is 1 to 4.
From the head of the array, 135 film, 240 film, and storage media are defined.

OutMediaSw [Output]

Defines the type of output media as follows:

Value	Description
QSS_OUTPMEDIA_NONE	No media output
QSS_OUTPMEDIA_FD	FD
QSS_OUTPMEDIA_CDR	CD-R
QSS_OUTPMEDIA_MO	MO
QSS_OUTPMEDIA_ZIP	ZIP
QSS_OUTPMEDIA_DVD	DVD
QSS_OUTPMEDIA_CF	Compact Flash
QSS_OUTPMEDIA_SM	Smart Media
QSS_OUTPMEDIA_PC	PC Card
QSS_OUTPMEDIA_HD	HD
QSS_OUTPMEDIA_CDRWSYS	CD-R Writing System
QSS_OUTPMEDIA_SD Δ7	SD Card
QSS_OUTPMEDIA_MS Δ7	Memory Stick
QSS_OUTPMEDIA_BRAVO Δ7	Bravo
QSS_OUTPMEDIA_USB Δ7	USB Flash Memory
QSS_OUTPMEDIA_XD_CARD Δ12-8	xD-Picture Card
QSS_OUTPMEDIA_MINI_SD Δ12-9	miniSD Card
QSS_OUTPMEDIA_MS_DUO Δ12-10	Memory Stick Duo
QSS_OUTPMEDIA_DVD_ROM Δ16-2	DVD+/-R/RW

OutMediaFormat [Output]

Defines the output format as follows:

Value	Description
QSS_MEDIA_FORMAT_NONE	None
QSS_MEDIA_FORMAT_JPEG	Jpeg
QSS_MEDIA_FORMAT_FPX	FlashPix
QSS_MEDIA_FORMAT_BMP	Bitmap
QSS_MEDIA_FORMAT_TIFF	TIFF

OutMediaInfoQuality [Output]

Defines the image quality.

OutMediaInfoQualityPer [Output]

Defines the quality ratio of the image to be saved to media. (unit: %)

OutMediaInfoSize [Output]

Defines the output size to media as follows:

Value	Description
-------	-------------

QSS_MEDIA_SIZE_NONE	None
QSS_MEDIA_SIZE_1P4	1/4 BASE
QSS_MEDIA_SIZE_1	BASE
QSS_MEDIA_SIZE_4	4 BASE
QSS_MEDIA_SIZE_16	16 BASE
QSS_MEDIA_SIZE_NONE_HS	None (HS)
QSS_MEDIA_SIZE_1P4_HS	1/4 BASE (HS)
QSS_MEDIA_SIZE_1_HS	BASE (HS)
QSS_MEDIA_SIZE_4_HS	4 BASE (HS)
QSS_MEDIA_SIZE_16_HS	16 BASE (HS)

PaperFitSW [Output]

Defines the type of paper fitting as follows:

Value	Description
QSS_PF_CUT	Cut
QSS_PF_WHOLE	Overall
QSS_PF_SAME	Real size

EditModeNo [Output]

Defines the edit type as follows:

Value	Description
QSS_EDIT_POST_CARD	Postcard
QSS_EDIT_BUSINESS_CARD	Business card
QSS_EDIT_CERTIFICATE_PHOTO	ID photo
QSS_EDIT_MULTI	Multi

Template [Output]

Defines the template type.

Bit assignment of template type is as follows (Bit 1: enabled, Bit 2: Disabled):

(There are cases where multiple templates are selected.)

0: C | 1: P | 2: H |

PapScan120 [Output]

Unused

Reserve [Output]

Unused

WSQSS_PU_INFO structure

```
typedef struct _WSQSS_PU_INFO {
    unsigned char    NameC[20];
    unsigned char    NameP[20];
    unsigned char    NameH[20];
    unsigned short   QuantityC;
    unsigned short   QuantityP;
    unsigned short   QuantityH;
    unsigned short   PriceC;
    unsigned short   PriceP;
    unsigned short   PriceH;
    unsigned long    SumC;
    unsigned long    SumP;
    unsigned long    SumH;
    unsigned long    ChargePrice;
}
```

```

        unsigned long      IndexPrice;
        unsigned char      Reserve[36];
    } WSQSS_PU_INFO;
    
```

Member:

NameC

NameP

NameH

Define the product name to be printed on the pricing sheet.

NameC: Name of Classical print

NameP: Name of Panoramic print

NameH: Name of High-definition print

NOTE: Although you may define a maximum of 19 characters, the number of characters actually printed on pricing sheet depends on the type of QSS model. (e.g. For QSS-28, QSS-29, QSS-30, and QSS-31, maximum number of characters to be printed is 5.)

QuantityC

QuantityP

QuantityH

Define the number of resultant prints to be printed on the pricing sheet.

QuantityC: Number of resultant Classical print

QuantityP: Number of resultant Classical Panoramic print

QuantityH: Number of resultant Classical High-definition print

When "0" is set the information related to the print size is not included in the pricing sheet.

NOTE: The range is 0 to 999.

PriceC

PriceP

PriceH

Define the unit price of each product to be printed on the pricing sheet.

PriceC: Unit price of Classical print

PriceP: Unit price of Panoramic print

PriceH: Unit price of High-definition print

NOTE: The range is 0 to 9999.

SumC

SumP

SumH

Define the total amount of each product to be printed on the pricing sheet.

SumC: Total amount of Classical prints

SumP: Total amount of Panoramic prints

SumH: Total amount of High-definition prints

NOTE: The range is 0 to 999999.

ChargePrice

Define the base price of a print.

NOTE: The range is 0 to 9999.

IndexPrice

Define the unit price of an index print.

NOTE: The range is 0 to 9999.

Reserve

Unused

Remarks:

Below is a sample of how the information listed above is allocated on a pricing sheet made by PU. (The order of

information is always Classical > Panoramic > High-definition.)

Name	Q'ty	Unit price	Sum
INPUT	1	<u>ChargePrice</u>	<u>ChargePrice</u>
<u>NameC</u>	<u>QuantityC</u>	<u>PriceC</u>	<u>SumC</u>
<u>NameP</u>	<u>QuantityP</u>	<u>PriceP</u>	<u>SumP</u>
<u>NameH</u>	<u>QuantityH</u>	<u>PriceH</u>	<u>SumH</u>
INDEX	*1 999		*2 999,999
TAX	*3 99.999 %		*4 999,999
Total amount	*5 (999,999)		*6 999,999

*1: Number of index print (range: 1 – 999)

*2: Number of index print times unit price (IndexPrice) (range: 0 – 999999)

*3: Tax rate whose setting is made on QSS (range: 0.000 – 99.999)

*4: Tax calculated with the tax rate whose setting is made on QSS (range: 0 – 999999)

*5: Price exclusive of tax (range: 0 – 999999)

*6: Price inclusive of tax (range: 0 – 999999)

As for tax rate, fractions, decimal point position, grouping symbol, ones whose setting has been made on QSS are applied.

Note:

Be sure to make setting of prices so they will fall in each allocated area on a pricing sheet.

WSQSS_SUM_INFO structure

```
typedef struct _WSQSS_SUM_INFO {
    unsigned long    PChC[100];
    unsigned long    PChP[100];
    unsigned long    PChH[100];
    unsigned long    PaperPrint;
    unsigned long    PaperIndex;
    unsigned long    PaperSetup;
    unsigned long    PaperLabel;
    unsigned long    PaperOther;
    unsigned long    PaperTotal;
    unsigned long    WriteMedia;
    unsigned long    WriteImage;
    unsigned short   DisposalSpec;
    unsigned long    TotalHojyu[9];
    unsigned char    Reserve[42];
} WSQSS_SUM_INFO;
```

Member:

PChC [Output]
 PChP [Output]
 PChH [Output]

Defines the total number of prints made in each print channel.

In the 0th of an array is the total number of prints from CH1, and in the 1st is that from CH2. Thus, the total numbers of prints in CH1 to CH99 are stored in this structure.

In the 99th is the total number of prints made from the external input source.

PChC: Total number of prints of Classical print
 PChP: Total number of prints of Panoramic print
 PChH: Total number of prints of High-definition print

PaperPrint [Output]
 PaperIndex [Output]
 PaperSetup [Output]
 PaperLabel [Output]
 PaperOther [Output]

Defines the total number of prints made by QSS.

PaperPrint: Total number of prints in Print Totals
 PaperIndex: Total number of prints in Index Print Totals
 PaperSetup: Total number of prints in Setup Print Totals
 PaperLabel: Total number of prints in Label Totals
 PaperOther: Total number of prints of Others
 PaperTotal: Total of PaperPrint, PaperIndex, PaperSetup, PaperLabel, and PaperOther.

WriteMedia [Output]
 WriteImage [Output]

Total number of media to which images have been written and total number of images written to media by QSS.

WriteMedia: Total number of media
 WriteImage: Total number of images written into media

DisposalSpec [Output]

Defines the process specification of QSS as follows:

Value	Description
QSS_SPEC_NORMAL	Standard spec.
QSS_SPEC_SM	SM spec.
QSS_SPEC_J	J spec.
QSS_SPEC_EX	EX spec.

TotalHojyu [Output]

Defines the total amount of replenisher solution used on QSS. (unit: ml)

The value stored in array varies depending on the process specification of QSS (DisposalSpec). Refer to the table below:

No	QSS_SPEC_NORMAL	QSS_SPEC_SM	QSS_SPEC_J	QSS_SPEC_EX
0	CD	CD-A	_____	CD-
1	BF	BF-A	_____	BF-A
2	STB	STB	_____	STB
3	_____	CD-B	_____	BF-B
4	_____	CD-C	_____	CD-W
5	_____	BF-B	_____	BF-W
6	_____	CD-W	_____	STB-W
7	_____	BF-W	_____	_____
8	_____	STB-W	_____	_____

Reserve
 Unused

WSQSS_PROFILE_INFO structure

```
typedef struct _WSQSS_PROFILE_INFO {
    unsigned short DeviceKind;
    unsigned short PaperWidth;
    unsigned short Surface;
```

```

    unsigned char    Reserve[26];
} WSQSS_PROFILE_INFO;

```

Member:

DeviceKind [Input]

Define the device whose profile you wish to get as follows:

Value	Description
QSS_PROFILE_MON	Get monitor profile.
QSS_PROFILE_PRN	Get printer profile.

PaperWidth [Input]

Define the paper width whose profile you wish to get. (unit: 1/10 mm)

NOTE: Use this member when you define QSS_PROFILE_PRN for DeviceKind.

Surface [Input]

Define the paper surface whose profile you wish to get.

The range is 1 to 4.

NOTE: Use this member when you define QSS_PROFILE_PRN for DeviceKind.

Reserve [Input]

Unused

WSQSS_DATETIME structure $\Delta 2$

```

typedef struct _WSQSS_DATETIME {
    unsigned short    Year;
    unsigned short    Month;
    unsigned short    Day;
    unsigned short    Hour;
    unsigned short    Minute;
} WSQSS_DATETIME;

```

Member:

Year [Output]

Define year (dominical year).

Month [Output]

Define month. The range is 1 – 12.

Day [Output]

Define day. The range is 1 – 31.

Hour [Output]

Define hour. The range is 0 – 23.

Minute [Output]

Define minute. The range is 0 – 59.

WSQSS_ORDER_HISTORY structure $\Delta 2$

```

typedef struct _QSS_ORDER_HISTORY {
    QSS_DATETIME    ReceiptTime;
    QSS_DATETIME    CompleteTime;
    unsigned short    ReceiptNo;
    unsigned short    Status;
    unsigned short    FrameNum;
}

```

```

unsigned short    PaperWidth;
unsigned short    Surface;
unsigned short    IndexPrintFlg;
unsigned short    PaperFittingFlg;
unsigned short    ReceiptFlg;
unsigned short    OrderNo;
char              Host[20];
char              User[20];
unsigned short    RequestNo;
unsigned char     Address[6];
unsigned short    PrintNumC;
unsigned short    PrintNumP;
unsigned short    PrintNumH;
unsigned short    IndexPrintNum;
unsigned short    MediaTotal;
unsigned short    OutputPrint;
unsigned short    OutputMedia;
unsigned short    CT1MediaOutput;
unsigned short    CT1OutputMedia;
QSS_DATETIME     PrintTime;
unsigned short    PaperWidthB;
unsigned short    SurfaceB;
unsigned short    Reserve1[6];
unsigned hyper    RefId;
unsigned char     Reserve[8];
} QSS_ORDER_HISTORY;

```

ReceiptTime [Output]

Defines the receipt time.

CompleteTime [Output]

Defines the printing completed time.

ReceiptNo [Output]

Defines the receipt number.

Status [Output]

Defines the order type as follows:

Value	Description
QSS_ORDER_PRINTED Δ14-2	Printed order
QSS_ORDER_NONE Δ14-3	Canceled order

FrameNum [Output]

Defines the total number of frames.

PaperWidth [Output]

Defines the paper width (unit: 1/10 mm).

Surface [Output]

Defines the paper surface.

IndexPrintFlg [Output]

Defines the index size. For detail, refer to IDPSize of [WSQSS_PRINT_CHANNEL structure](#).

PaperFittingFlg [Output]

Defines the type of paper fitting. For detail, refer to PaperFitSW of [WSQSS_PRINT_CHANNEL structure](#).

ReceiptFlg [Output]

Defines whether or not to issue order sheet.

Value	Description	
QSS_RECEIPT_ON	Issue order sheet.	
QSS_RECEIPT_OFF	Not issue order sheet.	
OrderNo		[Output]
Defines order number.		
Host		[Output]
Defines host name.		
User		[Output]
Defines user name.		
RequestNo		[Output]
Defines request number.		
Address		[Output]
Defines MAC address.		
PrintNumC		[Output]
PrintNumP		[Output]
PrintNumH		[Output]
Defines number of print.		
IndexPrintNum		[Output]
Defines number of index print.		
MediaTotal		[Output]
Defines number of media to which data is output.		
OutputPrint		[Output]
Defines whether to print or not.		
OutputMedia		[Output]
Defines the type of output media. For detail, refer to OutMediaSw of WSQSS_PRINT_CHANNEL structure .		
CT1MediaOutput		[Output]
Defines media output on CT-1. When the value is NOT 0, it means the media output is performed on CT-1.		
CT1OutputMedia		[Output]
Defines the type of output media used on CT-1. For detail, refer to OutMediaSw of WSQSS_PRINT_CHANNEL structure		
PrintTime		[Output]
Defines printing start time.		
PaperWidthB		[Output]
Defines paper width (unit: 1/10 mm).		
SurfaceB		[Output]
Defines paper surface.		
Reserve1		
Unused.		
RefId		[Output]
Defines reference number.		
Reserve		
Unused.		

WSQSS_FRAME_PARAM2 structure △9

```

typedef struct _WSQSS_FRAME_PARAM2 {
    unsigned short    OrderNo;
    unsigned short    FrameNum;
    unsigned short    FrameNo;
    unsigned char     FileName[18];
}

```

unsigned long	FileSize;		
unsigned long	ImageFormat;		
unsigned short	PrintSize;		
unsigned short	RepeatNum;		
unsigned short	RepeatPos;		
unsigned char	CvpString1[120];		
unsigned char	CvpString2[120];		
unsigned short	CvpFlg;		
unsigned short	PaperWidth;		
unsigned short	PaperLength;		
unsigned short	Surface;		
unsigned short	WithBorder;		△20-5
unsigned short	PaperFittingFlg;		△24-11
unsigned short	ImageXPixels;	// (Unused)	
unsigned short	ImageYPixels;	// (Unused)	
unsigned short	Reserve1;	// (Unused)	
unsigned_int64	RefId;		
unsigned short	SizeRate;	// (Unused)	
unsigned short	Rotate;		△17-1
short	CenterX;	// (Unused)	
short	CenterY;	// (Unused)	
unsigned short	TrimStartPointX;		△17-2
unsigned short	TrimStartPointY;		△17-3
unsigned short	TrimSizeX;		△17-4
unsigned short	TrimSizeY;		△17-5
unsigned short	TrimUnitSize;		△17-6
unsigned short	Save;		△20-6
unsigned short	EnablePaperFittingFlg;		△24-12
char	FrontPrintString[32];		△25-10
unsigned short	FrontPrintFlg;		△25-11
unsigned char	Reserve[24];		△25-12

} WSQSS_FRAME_PARAM2;

Member:

OrderNo		[Input]	
Request number			
The range is 0 – 65535. When 65535 (0xFFFF) is defined, an order will be added using the reference number as the administration key.			
FrameNum		[Input]	
Define the total number of frames an order consists of.			
The range is 1 to 9999.			△13-5
FrameNo		[Input]	
Define frame number.			
The range is 1 to 9999.			△13-6
FileName		[Input]	
Define the file name of the image to be sent to QSS.			
(Mainly used for index.)			
The string should be a maximum of 17 characters and NULL terminated.			
FileSize		[Input]	
Define the file size of the image to be sent to QSS. (unit: Byte)			
ImageFormat		[Input]	

Define the format of the image to be sent to QSS.

Define one of the formats defined in SupportImageFormat of QSS_PRINTER_STATE structure by calling QssGetPrinterState function.

You may define any image format to each individual frame.

PrintSize [Input]

Define print size as follows:

For values that can be set, refer to "PrintSize" of WSQSS_FRAME_PARAM structure.

RepeatNum [Input]

Define the number of repeat print to be made.

The range is 0 to 999.

NOTE: When you define 0, the frame will not be printed but included in index print.

RepeatPos [Input]

Define the position where repeat count (serial number) is printed as part of CVP (Correction Value Print).

0 to 117: 1st line of CVP

120 to 237: 2nd line of CVP

255: No repeat count number included in CVP.

CvpString1 [Input]

CvpString2 [Input]

Define the string to be printed as CVP.

CvpString1: String to be printed on the 1st line of CVP

CvpString2: String to be printed on the 2nd line of CVP

Set arbitrary Noritsu Character code. The strings must be NULL terminated.

The strings are a maximum of 115 characters, but the number of characters actually printed as CVP depends on the QSS model to be used and the advance length of the print.

When a setting is made with RepeatPos so the repeat count is printed as part of CVP, the values of repeat count (3 characters) will supersede the information that is supposed to be printed in the predetermined position where the values of repeat count are printed. △12-12

CvpFlg [Input]

Define whether the values for CVP will be the ones defined by QSS or in CvpString1 and CvpString2.

For values that can be set, refer to "CvpFlg" of WSQSS_FRAME_PARAM structure.

PaperWidth [Input]

Define width of the paper to be printed. (unit: 1/10mm)

You may define the same number of paper width as that can be installed to the connected QSS.

In case of QSS-31, you may define 2 different paper widths for an order.

In order to use this parameter, be sure to set QSS_PRINT_SIZE_FREE_C, QSS_PRINT_SIZE_FREE_P, or QSS_PRINT_SIZE_FREE_H in PrintSize.

PaperLength [Input]

Define the paper advance length for each frame (unit: 1/10 mm).

In order to use this parameter, be sure to set QSS_PRINT_SIZE_FREE_C, QSS_PRINT_SIZE_FREE_P, or QSS_PRINT_SIZE_FREE_H in PrintSize.

Surface [Input]

Define the surface type of the paper to be printed. The range is 1 to 4.

In order to use this parameter, be sure to set QSS_PRINT_SIZE_FREE_C, QSS_PRINT_SIZE_FREE_P, or QSS_PRINT_SIZE_FREE_H in PrintSize.

WithBorder [Input] △20-7

Define the size of the white border on the finished print. The range is 0-99. (Unit: 1/10 mm)

PaperFittingFlg [Input] △24-13

Define the paper fitting. For detail, refer to PaperFitSW of [WSQSS_PRINT_CHANNEL structure](#).

ImageXPixels

Unused

ImageYPixels

Unused

Reserve1

Unused

RefId

[Input]

Reference number

You may define any 64-bit identifier. Setting 0xFFFF to Request number (Order No) enables to add an order based on the reference number.

This also enables to use 64-bit data as administration key in case client manages orders. You may input any number between 1 and 99999999999999999 (19 digits).

SizeRate

Unused

Rotate

[Input]

△17-7

Define the desired rotation angle in increments of 0.1 degree so the image is oriented in the desired angle on the finished print. The range is 0 – 3599.

NOTE: With R2R machines, Rotate of the WSQSS_FRAME_PARAM structure is to be selected from 0, 90, 180, and 270 degree. With QSS, however, the desired rotation angle can be defined in increments of 0.1 degree to achieve more accurate adjustment.

CenterX

Unused

CenterY

Unused

TrimStartPointX

[Input]

△17-8

Define the cropping start position of the input image in the horizontal direction.

Unit can be defined in TrimUnitSize.

Refer to fig. 5 below for how to specify.

NOTE: When the input image is in portrait, it will be necessary to specify TrimStartPointX assuming that the image is rotated 270 degree.

TrimStartPointY

[Input]

△17-9

Define the cropping start position of the input image in the vertical direction.

Unit can be defined in TrimUnitSize.

Refer to fig. 5 below for how to specify.

NOTE: When the input image is in portrait, it will be necessary to specify TrimStartPointY assuming that the image is rotated 270 degree.

TrimSizeX

[Input]

△17-10

Define the cropping size of the input image in the horizontal direction.

Unit can be defined in TrimUnitSize.

Refer to fig. 5 below for how to specify.

NOTE: When the input image is in portrait, it will be necessary to specify TrimSizeX assuming that the image is rotated 270 degree.

TrimSizeY

[Input]

△17-11

Define the cropping size of the input image in the vertical direction.

Unit can be defined in TrimUnitSize.

Refer to fig. 5 below for how to specify.

NOTE: When the input image is in portrait, it will be necessary to specify TrimSizeY assuming that the image is rotated 270 degree.

TrimUnitSize

[Input]

△17-12

Define the unit for the parameters used for cropping (TrimStartPointX, TrimStartPointY, TrimSizeX, and TrimSizeY) as follows:

Value	Description
QSS_TRIM_UNIT_PIXEL	Pixel
QSS_TRIM_UNIT_PERCENT	Percent

Save

[Input]

△20-8

Define whether the image will be actually written to the media or not as follows:

QSS_OUTPMEDIA_NONE set in OutMediaFlg of the QSS_ORDER_PARAM2 structure supersedes this setting.

Value	Description
QSS_SAVE_ON	Image will be written to the media.

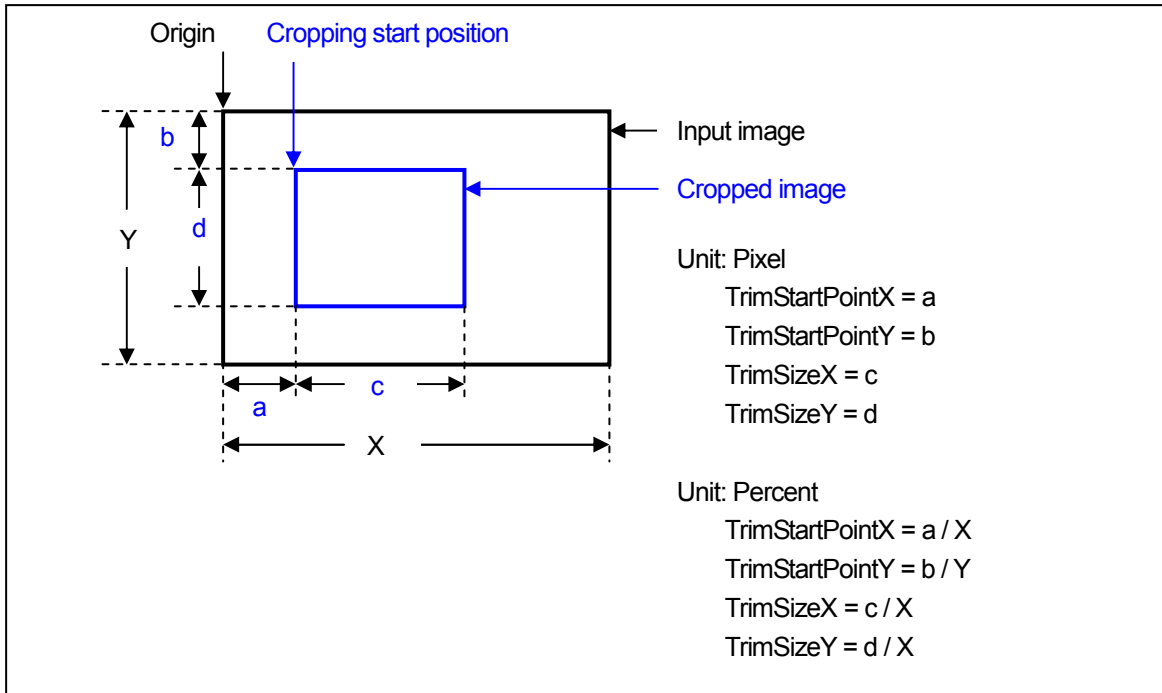

Fig. 5 Cropping of the input image

NOTE: When the input image is in portrait, it will be necessary to specify the start position and the size of the cropping assuming that the image is rotated 270 degree.

EnablePaperFittingFlg [Input] Δ 24-14

Set "0" in order not to use the paper fitting on a frame basis (PaperFittingFlag); otherwise set 1.

FrontPrintString [Input] Δ 25-13

Set text string for front print.

Any Noritsu character code can be used in the field, and the string must be NULL terminated.

31 characters can be set at maximum, but actual length of printed characters varies depending on each QSS model or paper advance length. Δ 26-1

FrontPrintFlg [Input] Δ 25-14

Set alignment method for front print. Choose one value from items below.

Value	Description
QSS_FP_NONE (0)	No front print
QSS_FP_RIGHT (1)	Front print text is right justified.
QSS_FP_LEFT (2)	Front print text is left justified.
QSS_FP_CENTER (3)	Front print text is center justified.

Reserve

Unused

WSQSS_ORDER_PARAM2 structure Δ 9

```
typedef struct _WSQSS_ORDER_PARAM2 {
    unsigned short    OrderNo;
    unsigned short    FrameNum;
    unsigned short    PaperWidth;
    unsigned short    PaperLengthC;
    unsigned short    PaperLengthP;
    unsigned short    PaperLengthH;
    unsigned short    Surface;
}
```

unsigned short	WithBorderC;		
unsigned short	WithBorderP;		
unsigned short	WithBorderH;		
unsigned short	IndexPrintFlg;		
unsigned short	PaperFittingFlg;		
unsigned short	IndexPaperWidth;		
unsigned short	IndexSurface;		
unsigned short	CmsFlg;		
unsigned short	OrderPunch;	// (Unused)	
unsigned_int64	RefId;		
unsigned short	ManualCut;	// (Unused)	
char	Comment[22];		△25-15
unsigned short	SorterNum;		
unsigned short	PaperWidthB;		
unsigned short	SurfaceB;		
unsigned short	PaperWidthC;		
unsigned short	SurfaceC;		
unsigned short	IndexPrintNum;		△18-1
unsigned short	OutMediaFlg;		△18-2
unsigned short	OutMediaFormat;		△18-3
unsigned short	OutMediaNum;		△18-4
unsigned short	OutMediaQualityType;		△18-5
unsigned short	OutMediaQuality;		△18-6
unsigned short	OutMediaSize;		△18-7
unsigned short	OutMediaViewer;		△18-8
unsigned short	LabelIndexPrintFlg;		△18-9
unsigned short	LabelIndexNum;		△18-10
unsigned short	LabelIndexPaperWidth;		△18-11
unsigned short	LabelIndexSurface;		△18-12
unsigned short	EnablePriority;		△22-1
unsigned short	Priority;		△18-13
unsigned short	PrintMode;		△18-14
unsigned short	Wait;		△18-15
unsigned short	PaperWidthD;		△25-3
unsigned short	SurfaceD;		△25-4
unsigned char	Reserve[146];		△22-2, △25-5
} WSQSS_ORDER_PARAM2;			

Member:

OrderNo		[Input]	
Define request number.			
The range is 0 – 65535. When 65535 (0xFFFF) is defined, an order will be added using the reference number as the administration key.			
FrameNum		[Input]	
Define total number of frames an order consists of.			
The range is 1 to 9999.			
PaperWidth		[Input]	
Define width of the paper to be printed. (unit: 1/10mm)			
PaperLengthC		[Input]	
PaperLengthP		[Input]	
PaperLengthH		[Input]	
Define advance length of the paper. (unit: 1/10mm)			

△13-7

PaperLengthC: Define paper advance length for Classical size print.

PaperLengthP: Define paper advance length for Panoramic size print.

PaperLengthH: Define paper advance length for High-definition size print

Be sure to define paper length that falls between the minimum and maximum paper lengths (PaperLengthMin and PaperLengthMax) of the paper information (WSQSS_PAPER_INFO). △15-6

Surface [Input]

Define the surface type of the paper to be printed.

The range is 1 to 4.

WithBorderC [Input]

WithBorderP [Input]

WithBorderH [Input]

Define the width of the white boarder of the resultant print (range: 0-99, unit: 1/10mm)

When you define 0, resultant print will have no border.

WithBorderC: Define the width of white boarder for Classical size print.

WithBorderP: Define the width of white boarder for Panoramic size print.

WithBorderH: Define the width of white boarder for High-definition size print.

IndexPrintFlg [Input]

Define the page size of index print.

For values that can be set, refer to “IndexPrintFlg” of WSQSS_ORDER_PARAM structure.

Number of frames to be printed on an index print will be calculated automatically based on the size of the index print to be made and the number of frames included in the order.

PaperFittingFlg [Input]

Define the type of paper fitting to apply to the image, based on the print size.

For values that can be set, refer to “IndexPrintFlg” of WSQSS_ORDER_PARAM structure.

IndexPaperWidth [Input]

Define the width of the paper where index print is to be printed. (unit: 1/10mm)

IndexSurface [Input]

Define the surface type of the paper where index print is to be printed. The range is 1 – 4.

CmsFlg [Input]

Define whether or not to apply QSS CMS to the received order.

For values that can be set, refer to “CmsFlg” of WSQSS_ORDER_PARAM structure.

OrderPunch

Unused.

RefId [Input]

Reference number.

You may define any 64-bit identifier. Setting 0xFFFF to Request number (Order No) enables to add an order based on the reference number.

This also enables to use 64-bit data as administration key in case Client manages orders. You may input any number between 1 and 999999999999999999 (19 digits).

ManualCut

Unused.

Comment [Input] △25-16

Define the comment string.

The string must be NULL terminated.

SorterNum [Input] △5

You may define how many prints are placed on a receiver of the sorter before sorter moves.

The range is 0 – 120.

When you define 0, the sorter will move when the maximum number of prints that a receiver can hold is placed on a receiver.

SorterNum is available with the NetOrder API of version 1.0.6 or up.

With earlier version of NetOrder API, this value is fixed to 0.

Client is requested to set the version of the NetOrder API that it uses to Version of QSS_CLIENT_INFO.

When the version in use is 1.0.6, set 0x01000600 to Version.

This is not available with QSS-30.

PaperWidthB	[Input]	
SurfaceB	[Input]	
PaperWidthB: Define the width of the paper to be printed. (unit: 1/10 mm) SurfaceB: Define the surface type of the paper to be printed. The range is 1-4. When 2 different papers are to be used within an order, define the width and surface type of the second paper. Set 0 in the following cases: Only 1 paper is used for an order. The connected QSS is of single-magazine type.		
PaperWidthC	[Input]	
SurfaceC	[Input]	
PaperWidthC: Define the width of the paper to be printed. (unit: 1/10 mm) SurfaceC: Define the surface type of the paper to be printed. The range is 1 – 4. When 3 different papers are to be used within an order, define the width and surface type of the third paper. Set 0 in the following cases: Only 1 or 2 paper(s) is(are) used for an order. The connected QSS is of single- or double-magazine type.		
IndexPrintNum	[Input]	△18-16
Define the number of index print to be created. The range is 1 – 999. IndexPrintNum is only available with the NetOrder API version 2.1.0 or forward. When the client uses the earlier version of NetOrder API, this value will be ignored and fixed to 1. When using IndexPrintNum, be sure to set a value bigger than 0x02010000 in Version of WSQSS_CLIENT_INFO.		
OutMediaFlg	[Input]	△21-1 △18-17
Define the destination of output to media. For the possible values, refer to OutMediaSw of the WSQSS_PRINT_CHANNEL structure. When QSS_OUTPMEDIA_NONE is defined, output to media will not be performed.		
OutMediaFormat	[Input]	△18-18
Define the media output format. For the possible values, refer to OutMediaFormat of the WSQSS_PRINT_CHANNEL structure. When QSS_OUTPMEDIA_NONE is defined in OutMediaFlg, the value specified here will be ignored.		
OutMediaNum	[Input]	△18-19
Define the number of media to be created. The range is 1 – 99. When QSS_OUTPMEDIA_NONE is defined in OutMediaFlg, the value specified here will be ignored.		
OutMediaQualityType	[Input]	△18-20
Define the media output quality as follows: When QSS_OUTPMEDIA_NONE is defined in OutMediaFlg, the value specified here will be ignored. This setting is only applicable when OutMediaFormat is set to either QSS_MEDIA_FORMAT_JPEG or QSS_MEDIAFORMAT_FPX.		
		△21-2
	Value	Description
	QSS_MEDIA_QUALITY_STANDARD	QSS's "Standard"
	QSS_MEDIA_QUALITY_Q1	QSS's "Quality 1"
	QSS_MEDIA_QUALITY_Q2	QSS's "Quality 2"
	QSS_MEDIA_QUALITY_Q3	QSS's "Quality 3"
	QSS_MEDIA_QUALITY_SET	Quality specified by client with OutMediaQuality.
	QSS_MEDIA_QUALITY_FIXED	Fixed value that QSS internally has.
OutMediaQuality	[Input]	△18-21
Specify the media output quality in percent (%). The range is 1 – 99. When OutMediaFlg is set to QSS_OUTPMEDIA_NONE, the value specified here will be ignored. This setting is only applicable when OutMediaFormat is set to either QSS_MEDIA_FORMAT_JPEG or QSS_MEDIAFORMAT_FPX and when OutMediaQualityType is set to QSS_MEDIA_QUALITY_SET.		
OutMediaSize	[Input]	△18-22
Define the media output size. For the possible values, refer to OutMediaInfoSize of the WSQSS_PRINT_CHANNEL structure. When OutMediaFlg is set to QSS_OUTPMEDIA_NONE, the value specified here will be ignored.		
OutMediaViewer	[Input]	△18-23
Specify the type of the viewer to be included when writing data to CD. For the possible values, refer to EnableOutMediaViewer of the WSQSS_PRINTER_STATE structure.		

When OutMediaFlg is set to QSS_OUTPMEDIA_NONE, the value specified here will be ignored.

This setting is only applicable when OutMediaFlg is set to QSS_OUTPMEDIA_CDR, QSS_OUTPMEDIA_CDRWSYS, or QSS_OUTPMEDIA_BRAVO. △21-4

LabelIndexPrintFlg [Input] △18-24

Specify whether or not to perform label index printing as follows:

When OutMediaFlg is set to QSS_OUTPMEDIA_NONE, or when media that QSS label index print function does not support is selected, the value specified here will be ignored. △21-5

Value	Description
QSS_LABEL_OFF	Label index printing will not be performed.
QSS_LABEL_ON	Label index printing will be performed.

LabelIndexPrintNum [Input] △18-25

Define the number of label index print to create. The range is 1 – 99.

When LabelIndexPrintFlg is set to QSS_LABEL_OFF, the value specified here will be ignored.

LabelIndexPaperWidth [Input] △18-26

Define the width of the paper on which label index will be printed. (Unit: 1/10 mm)

When LabelIndexPrintFlg is set to QSS_LABEL_OFF, the value specified here will be ignored.

LabelIndexSurface [Input] △18-27

Define the surface type of the paper on which label index will be printed. The range is 1 – 4.

When LabelIndexPrintFlg is set to QSS_LABEL_OFF, the value specified here will be ignored.

EnablePriority [Input] △22-3

Set 0 when Priority is not used, and 1 when used.

Priority [Input] △18-28

Specify the priority of the order. The range is 0 – 65535.

Priority is only available with NetOrder API version 2.1.0 or forward. When the client uses an earlier version of NetOrder API, then the value specified here will be ignored and fixed to “Normal” priority (QSS_PRIORITY_NORMAL).

When Priority is used, set a value bigger than 0x02010000 in Version of WSQSS_CLIENT_INFO and 1 in EnablePriority. When EnablePriority is not set to 1, Priority will be ignored. △22-4

With QSS, values are rounded as follows: △21-6

Value	Possible value	Description
QSS_PRIORITY_HIGHEST	0 – 99	Highest priority
QSS_PRIORITY_HIGH	100 – 199	High priority
QSS_PRIORITY_NORMAL	200 – 299	Normal
	△23-1	
QSS_PRIORITY_LOW △23-2	300 – 65534	Low priority
QSS_PRIORITY_NONE △23-3	65535	No priority specified

PrintMode [Input] △18-29

Define the printing method as follows:

Value	Description
QSS_PRINT_MODE_AUTO	AUTO
QSS_PRINT_MODE_PJP	PJP
QSS_PRINT_MODE_PPI	PPI

Wait [Input] △18-30

Define whether or not to suspend processing of order when receiving another order as follows:

Value	Description
QSS_WAIT_OFF	Upon completion of receiving an order, the order state will be set to “Print queue”. (When print data is completely received, printing will start as far as it is ready for printing.)
QSS_WAIT_ON	Upon completion of receiving an order, the order state will be set to “Order reserved”.

PaperWidthD [Input] △25-6

SurfaceD [Input] △25-7

PaperWidthD: Define the width of the paper to be printed. (unit: 1/10 mm)

SurfaceD: Define the surface type of the paper to be printed. The range is 1 – 4.

When 4 different papers are to be used within an order, define the width and surface type of the fourth paper. Set 0 in the following cases:

The order requires up to 3 paper magazines.

The connected QSS is of single- or double- or triple- magazine type.

Reserve

Reserved (Unused)

Remarks:

For PaperWidth, Surface, IndexPaperWidth, IndexPaperWidth, IndexSurface, PaperWidthB, SurfaceB, PaperWidthC, SurfaceC, LabelIndexPaperWidth, LabelIndexSurface, PaperWidthD and SurfaceD, define the value of the paper that has been registered on QSS. You may get information on the registered paper by using QssGetPaper function. Δ25-8

PaperWidth, Surface, IndexPaperWidth, IndexSurface, PaperWidthB, SurfaceB, PaperWidthC, SurfaceC, LabelIndexPaperWidth, LabelIndexSurface, PaperWidthD and SurfaceD are used to confirm the corresponding paper magazines are installed when printing the order that are spooled in the QSS. Δ25-9

NOTE:

In case of single-magazine QSS, paper must be consistent between normal print (PaperWidth and Surface) and index print (IndexPaperWidth and Index Surface).

WSQSS_RESULT structure

```
typedef struct _WSQSS_RESULT {
    unsigned long      ReturnValue;
    unsigned char      Reserve[28];
} WSQSS_RESULT;
```

Δ15-1

Member:

ReturnValue

Define the result of request process as follows:

Value	Description
QSS_SUCCESS	Request process succeeded
QSS_FAIL	Request process failed
QSS_INVALID_ORDERNO	Request number is illegal.
QSS_INVALID_FRAMENO	Frame number is illegal.
QSS_NOT_SUPPORT_FORMAT	Image format is not supported.
QSS_INVALID_REPEATNUM	Repeat number is illegal.
QSS_DISKFULL_SPOOL	Insufficient free space in spool region.
QSS_INVALID_FRAMENUM	Number of frame is illegal.
QSS_INVALID_PAPER	Cannot use the paper specified.
QSS_INVALID_WBSIZE	White boarder width is illegal.
QSS_INVALID_INDEXSIZE	Index print size is illegal.
QSS_INVALID_PAPERFITTING	Paper fitting is illegal.
QSS_INVALID_ID_AUTHORITY	No authority to delete.
QSS_NO_SUCH_ORDER	Cannot find an order.
QSS_NOT_CONNECTED_PU	PU is not installed.
QSS_REMAINING_DATA	There is unacquired data.
QSS_DISABLE_MODE	Orders are not acceptable in the selected mode. Δ10-1
QSS_INVALID_PAPERLENGTH	Paper advance length is illegal.
QSS_RECEIVE_ABORT	Order receipt was denied.

	(e.g. The order was deleted on QSS while being received.)
QSS_NOTEXIST_PROFILE	Profile does not exist. Δ2
QSS_NOT_CONNECTED	Cannot connect to the Client. Δ2
QSS_ILLEGAL_IMAGEDATA	Image file is illegal. Δ10-2
QSS_INVALID_IMAGESIZE	Image file size is illegal. Δ10-3
QSS_INVALID_OUTMEDIA_PARAM	Invalid parameter for media output Δ20-9
QSS_INVALID_PARAMETER	Invalid parameter Δ21-7
Reserve	
Unused	

4. QSS Search function

This chapter describes the function to search QSS connected to Ethernet from printer driver.

1. Interface

This function uses UDP for protocol.

2. Sequence

Printer driver sends inquiry message (packet) to QSS. Once QSS receives the message, it returns the response message to the sender of the message. Printer driver can get QSS model and IP address from the response message that QSS returns.

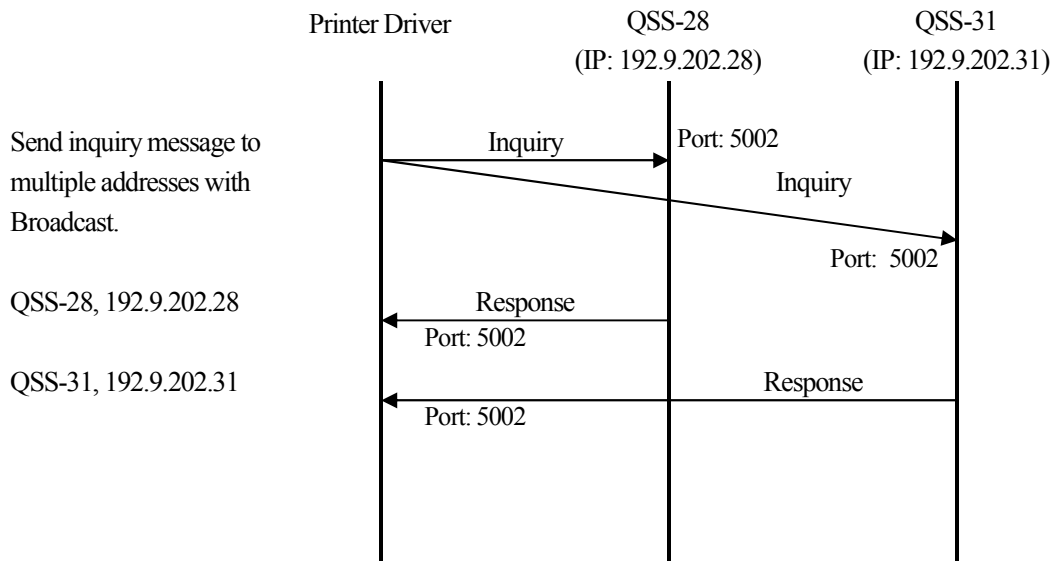

Fig. 1. Search sequence

NOTE: IP address of QSS varies from unit to unit.

3. Message format

Though QSS and printer driver send and receive Ethernet frame, they both use application data only. Byte order is of little endian which is the network standard.



Fig. 2. Ethernet frame

Inquiry message

0 x 000F	0 x 0001	Reserved
2 (Byte)	← 2 →	← 40 →

Response message

0 x 000F	0 x 0002	Model name	IP address	Printer resolution	Reserved
2 (Byte)	← 2 →	← 20 →	← 4 →	← 2 →	← 14 →

Model name

Stores QSS model name.

Model	Model name
QSS-28	QSS-28
QSS-29	QSS-29
QSS-30	QSS-30
QSS-31	QSS-31

IP address

Stores IP address of QSS.

Printer resolution

Stores default printer resolution.

Appendix: Noritsu Character Code Table Δ12-12

Refer to the following control codes to switch SI and SO codes. For example, to print the copyright mark in SO code, set the following 3 codes in the print data: 0x0e, 0xC1, and 0x0f.

Control code	Description
0x0F	Switch to SI code.
0x0E	Switch to SO code.
0x0D	Switch to SI code (double-size character).
0x0C	Switch to SO code (double-size character).

Table 1: Noritsu Character Code Table (SI code)

		Upper																											
		0	0	0	0	0	0	0	0	1	1	1	1	1	1	1	1												
Lower		Lower																											
		0	1	2	3	4	5	6	7	8	9	A	B	C	D	E	F												
0	0	0	0	0	0	0	0	0	0	1	1	1	1	1	1	1	SP	0	@	P	`	p				~	タ	ミ	
0	0	0	1	1	0	0	1	1	0	0	0	0	1	1	1	1	!	1	A	Q	a	q				。	ア	チ	ム
0	0	1	0	0	1	1	0	0	1	1	0	1	1	0	0	1	"	2	B	R	b	r				「	イ	ッ	メ
0	0	1	1	0	0	1	0	1	0	1	0	1	0	1	0	1	#	3	C	S	c	s				」	ウ	テ	モ
0	1	0	0	0	1	0	1	0	1	0	1	0	1	0	1	0	\$	4	D	T	d	t				、	エ	ト	ヤ
0	1	0	1	0	1	0	1	0	1	0	1	0	1	0	1	0	%	5	E	U	e	u				・	オ	ナ	ユ
0	1	1	0	0	1	0	1	0	1	0	1	0	1	0	1	0	&	6	F	V	f	v				ヲ	カ	ニ	ヨ
0	1	1	1	0	0	1	0	1	0	1	0	1	0	1	0	1	'	7	G	W	g	w				ァ	キ	ヌ	ラ
1	0	0	0	0	1	0	1	0	1	0	1	0	1	0	1	0	(8	H	X	h	x				イ	ク	ネ	リ
1	0	0	1	0	0	1	0	1	0	1	0	1	0	1	0	1)	9	I	Y	i	y				ウ	ケ	ノ	ル
1	0	1	0	0	1	0	1	0	1	0	1	0	1	0	1	0	*	:	J	Z	j	z				エ	コ	ハ	レ
1	0	1	1	0	0	1	0	1	0	1	0	1	0	1	0	1	+	;	K	[k	{				オ	サ	ヒ	ロ
1	1	0	0	0	1	0	1	0	1	0	1	0	1	0	1	0	,	<	L	\	l					ヤ	シ	フ	ワ
1	1	0	1	0	0	1	0	1	0	1	0	1	0	1	0	1	-	=	M]	m	}				ユ	ス	ハ	ン
1	1	1	0	0	1	0	1	0	1	0	1	0	1	0	1	0	.	>	N	^	n	~				ヨ	セ	キ	ク
1	1	1	1	0	0	1	0	1	0	1	0	1	0	1	0	1	/	?	O	_	o					ッ	ソ	マ	・

Table 2: Noritsu Character Code Table (SO code)

		Upper															
		0	0	0	0	0	0	0	0	1	1	1	1	1	1	1	1
Lower		Lower															
		0	1	2	3	4	5	6	7	8	9	A	B	C	D	E	F
0	0	0	0	0													
0	0	0	1	1													
0	0	1	0	0													
0	1	0	0	0													
0	1	0	1	0													
0	1	1	0	0													
0	1	1	1	0													
1	0	0	0	0													
1	0	0	1	0													
1	0	1	0	0													
1	0	1	1	0													
1	1	0	0	0													
1	1	0	1	0													
1	1	1	0	0													
1	1	1	1	0													
1	1	1	1	1													